



User Guide

Network Video Recorder

Contents

About This Guide	1
Get Started	2
1.1 Connect the Hardware.....	3
1.2 Set Up NVR.....	4
Live View	7
2.1 Configure the Screen Layout.....	8
2.2 Configure Live View Settings via Toolbar.....	9
Playback	10
3.1 Instant Playback.....	11
3.2 Play Normal Recordings.....	11
3.3 Playback Recordings of Events.....	12
3.4 Playback Operations	14
3.4.1 Edit Recordings.....	15
Configure Your Network Camera	16
4.1 Add Cameras to the NVR.....	17
4.1.1 Add Cameras Singly or in Batches	17
4.1.2 Add a Camera to a Certain Screen.....	20
4.1.3 Add Cameras Manually.....	21
4.1.4 Modify IP Addresses of Cameras.....	22
4.2 Plug and Play Settings	23
4.3 Configure Image Effects	23
4.3.1 Configure Image Settings.....	23
4.3.2 Configure OSD Setting.....	26
4.3.3 Configure Privacy Mask	27
4.4 Configure Stream Settings	28
4.4.1 Configure Videos.....	28
4.4.2 Configure Audio.....	30
4.4.3 Configure SRTP Settings	31
4.5 Events	31
4.5.1 Alarm Schedule and Triggered Action.....	31
4.5.2 Motion Detection.....	34

4. 5. 3	Line Crossing Detection.....	35
4. 5. 4	Intrusion Detection	36
4. 5. 5	Camera Tampering.....	38
4. 6	Manage Your Cameras	39
4. 6. 1	Modify Camera Connection Parameters.....	39
4. 6. 2	Change the Password and Reset Email	39
4. 6. 3	Configure Scheduled Reboot.....	40
4. 6. 4	Upgrade the Firmware.....	41
4. 6. 5	Remove Cameras from the NVR.....	42
 Search		 43
5. 1	Search for Videos	44
 System		 45
6. 1	Configure Alarm Settings	46
6. 1. 1	System Exception	46
6. 1. 2	Video Signal Loss	46
6. 1. 3	Alarm Device	47
6. 1. 4	Arming/Disarming.....	51
6. 2	Storage.....	54
6. 2. 1	Configure Recording Schedules.....	54
6. 2. 2	Recording Controls	56
6. 2. 3	Hard Drive Management.....	58
6. 2. 4	Expansion Storage.....	59
6. 2. 5	Long-term Storage.....	59
6. 3	Configure Network Settings.....	60
6. 3. 1	Configure Connection Settings.....	60
6. 3. 2	Network Service	62
6. 3. 3	Configure PoE Channel.....	65
6. 3. 4	Configure Platform Access.....	66
6. 3. 5	Configure Email.....	67
6. 3. 6	Configure FTP	68
6. 3. 7	Configure DDNS.....	70
6. 3. 8	Configure UPnP	70
6. 3. 9	Configure LLDP	71
6. 3. 10	Configure SNMP.....	71
6. 3. 11	Network Isolation	73
6. 3. 12	Configure IP Restriction	73

6.4	Configure General Settings	74
6.4.1	Configure Basic Settings.....	74
6.4.2	Modify System Time	74
6.4.3	Configure Interface Output.....	75
6.4.4	User Management.....	76
6.4.5	Firmware Update	78
6.4.6	Maintenance.....	79
6.4.7	Reboot Schedule	80
6.4.8	Login Settings.....	80
6.4.9	IP Restriction	80
6.4.10	System Log.....	81

About This Guide

This User Guide provides information for using and managing NVR. It explains the GUI functions of NVR and shows you how to configure them.

Conventions

When using this guide, notice that:

- Features available in NVR may vary due to your region, device model, and firmware version. All images, steps, and descriptions in this guide are only examples and may not reflect your actual experience.
- The information in this document is subject to change without notice. Every effort has been made in the preparation of this document to ensure accuracy of the contents, but all statements, information, and recommendations in this document do not constitute the warranty of any kind, express or implied. Users must take full responsibility for their application of any products.
- This guide uses the specific formats to highlight special messages. The following table lists the conventions that are used throughout this guide.

<u>Underlined</u>	Indicates hyperlinks. You can click to redirect to a website or a specific section.
Bold	Indicates contents to be emphasized and texts on the web page, including the menus, tabs, buttons and so on.
>	The menu structures to show the path to load the corresponding page.
Caution	Reminds you to be cautious, and Ignoring this type of note might result in device damage or data loss.
Note	Indicates information that helps you make better use of your device.

More Information

- The latest software and documentations can be found at <https://support.omadanetworks.com/document/>.
- The Installation Guide (IG) can be found where you find this guide or inside the package of the NVR.
- Specifications can be found on the product page at <https://www.omadanetworks.com/>.
- Our Technical Support contact information can be found at the Contact Technical Support page at <https://support.omadanetworks.com/>.



Get Started

This chapter guides you on how to set up your NVR for the first time. The quick setup wizard brings you convenience and flexibility to configure the NVR. This chapter includes the following sections:

- [Connect the Hardware](#)
- [Set Up NVR](#)

The Omada network video recorder (NVR) coordinates with camera systems to help you view, store, and playback videos. With the support of ONVIF, you can easily add cameras of different brands. Also, it supports detecting events and sending you up-to-date notifications. Moreover, you can manage and monitor the NVR and cameras remotely via the Omada Guard app.

1.1 Connect the Hardware

To manage multiple cameras, you should prepare a network device, such as a switch or a router. Connect the NVR and cameras to the network device to ensure they are in the same network. Follow the steps below to connect the devices.

Follow the steps below to complete the hardware connection.

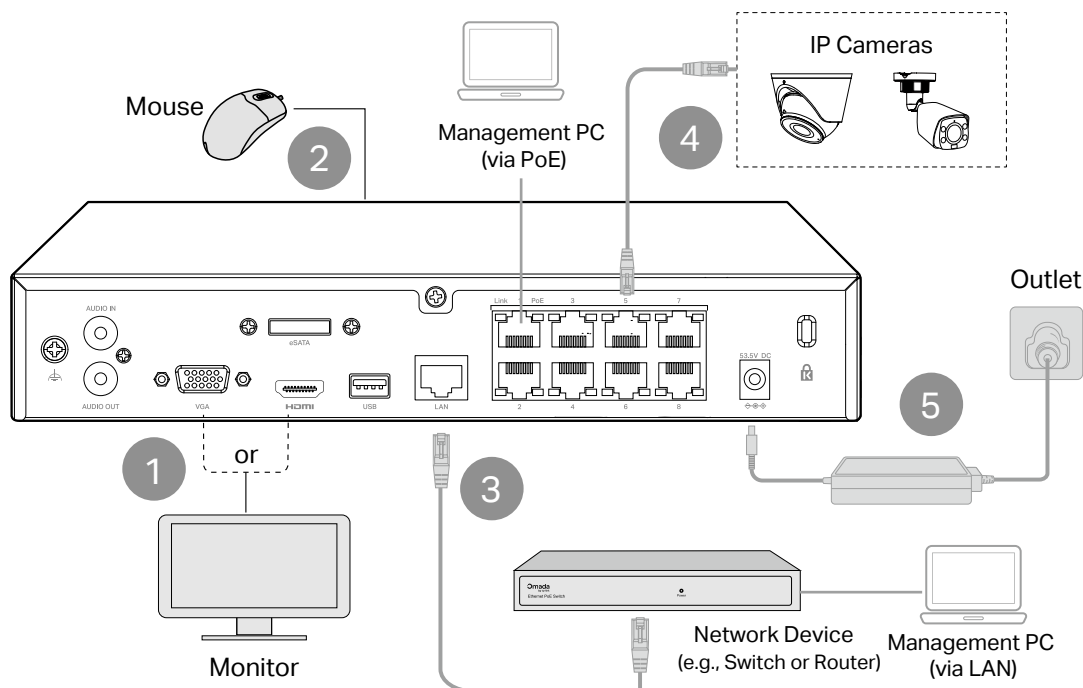

1. Connect your monitor to the HDMI or VGA port according to the connection port it supports, and Connect your monitor to a power source.
2. Connect the provided USB Mouse to the USB Interface of the NVR.
3. Connect the LAN port of the NVR to a network device with an Ethernet cable.
4. Connect the cameras to the network device.
5. Connect the power adapter to the NVR.
6. Turn on the monitor and you will enter the NVR's GUI.

Note: The NVR can also be configured and managed via the Omada Guard app and web UI. The default web login address is <https://192.168.0.240> (via LAN port) or <https://192.168.253.1> (via PoE port).

1.2 Set Up NVR

With an user interface displayed on monitor, it is easy to configure and manage the NVR. You will see the following page.

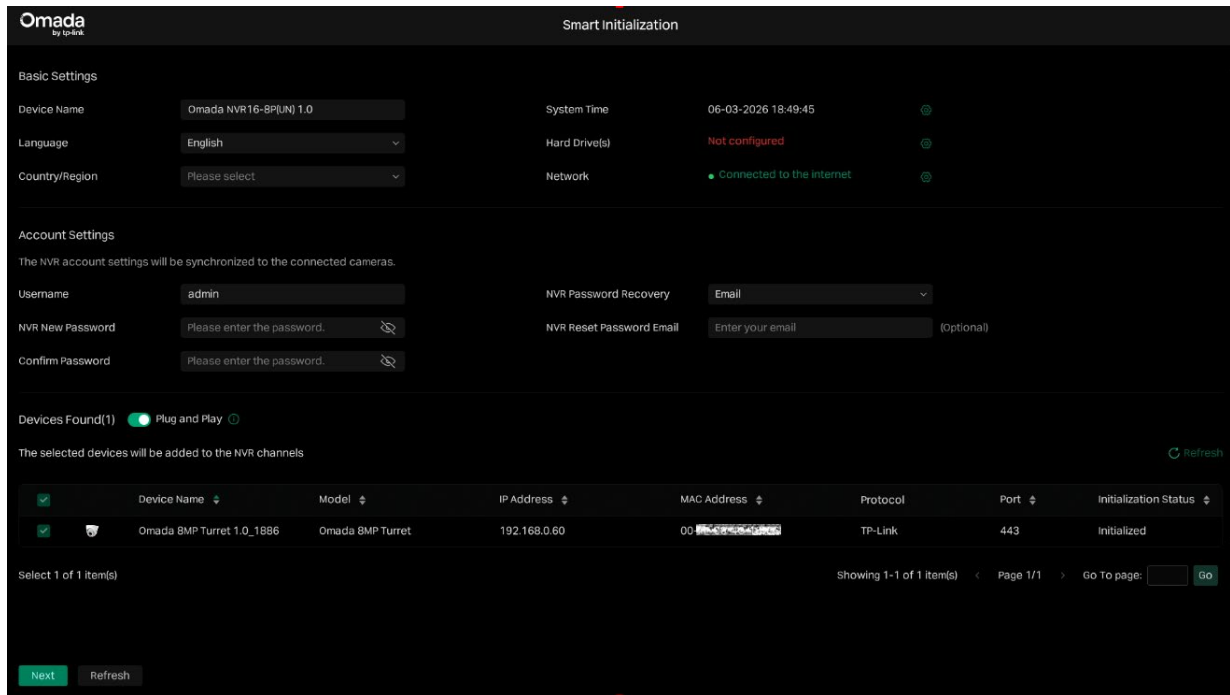

1. Confirm the Basic Settings.

Device Name	Displays the name of the device. You can change it as needed.
Language	Set the system language of the NVR.
Country/Region	Set your region.
System Time	Displays the system time of the NVR. You can click the Settings button to configure the time settings. Refer to Modify System Time for detailed instructions.
Hard Drive(s)	Displays the external hard drive details.
Network	Displays the network connection status of the NVR. You can click the Settings button to configure the network settings. Refer to Configure Network Settings for detailed instructions.

2. Configure the account settings. The NVR account settings will be synchronized to the connected cameras.

Username	Displays the name used to log in to the NVR. It is admin by default.
New Password	Set the password of your NVR.
Confirm Password	Confirm the password of your NVR.

NVR Password Recovery

(Optional) Set an email address or security questions to reset the password of your NVR.

3. Select the device you want to add automatically and click **Next**.
4. You can use the Omada Guard app to access the device via Omada cloud service. Click **Confirm**.

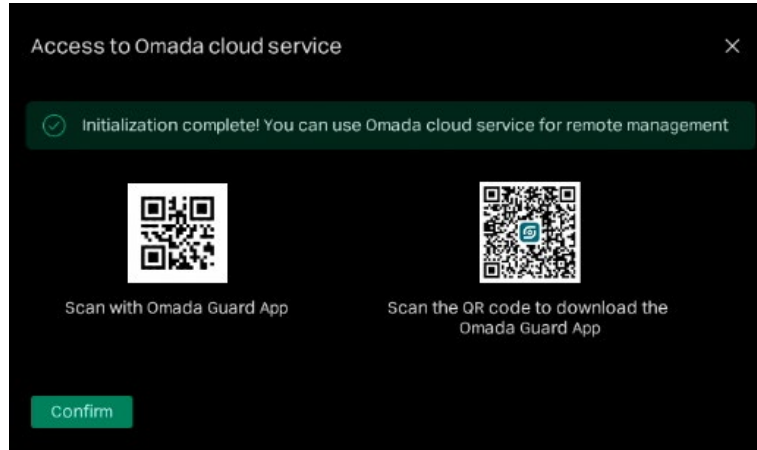

5. Set the pattern password for easy login. If you don't want a pattern password, click **Skip**.

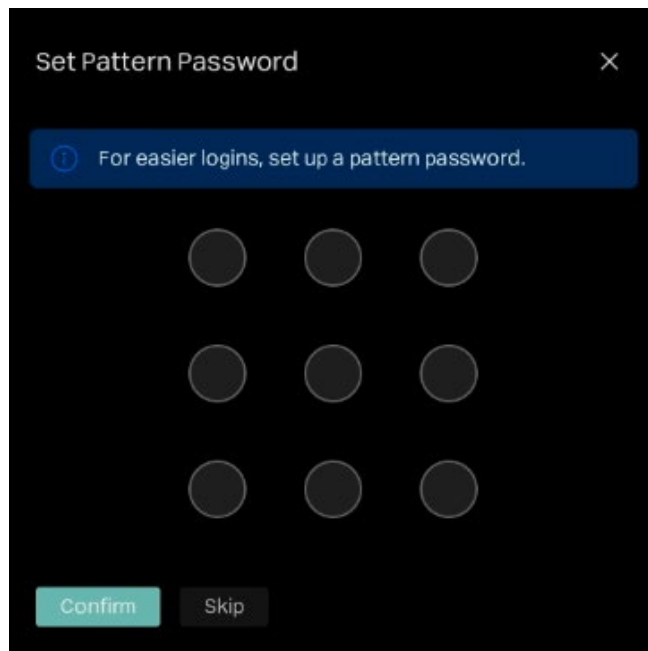

6. Done. The set up is complete, and you will enter the full screen preview page. This page displays the connected channels, system running time, real-time throughput, camera capacity, CPU utilization and event filter.

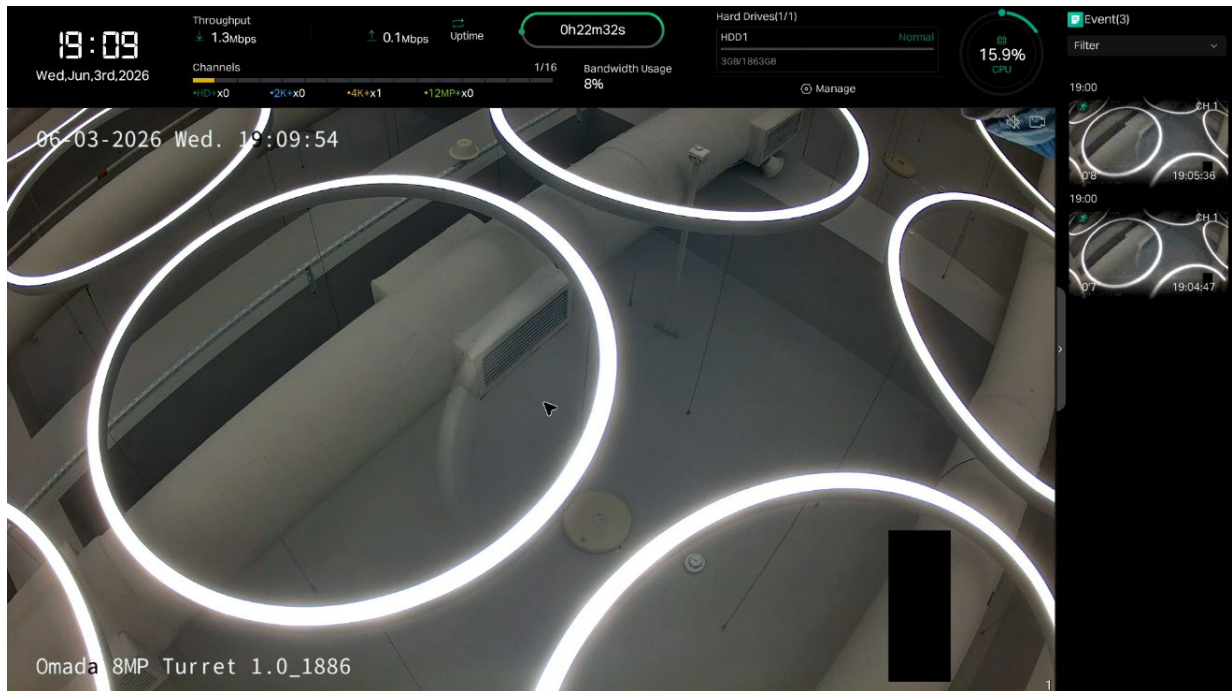

7. Move your mouse to the top edge of the screen and you will see a menu icon  in the upper left corner, and you can click it to open the menu.

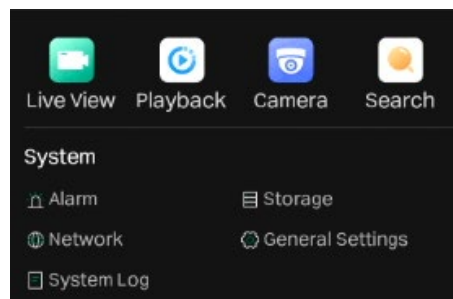



2

Live View

In Live View, you can monitor the channels in real time and respond to abnormal conditions with quick operations, such as viewing instant playback, zooming in the image, and enabling real-time talk. This chapter contains the following sections:

- [Configure the Screen Layout](#)
- [Configure Live View Settings via Toolbar](#)

2.1 Configure the Screen Layout

The NVR displays the videos of each channel via several screens. The NVR supports multiple layout modes, which display multiple screen(s) in one page separately. To change the screen layout, right click on the Live View screen and click the  screen layout icon, or directly click the  screen layout icon at the right lower corner of the screen (when not in full screen preview), or you can go to **System > General Settings > Screen Layout** to configure the screen layout.

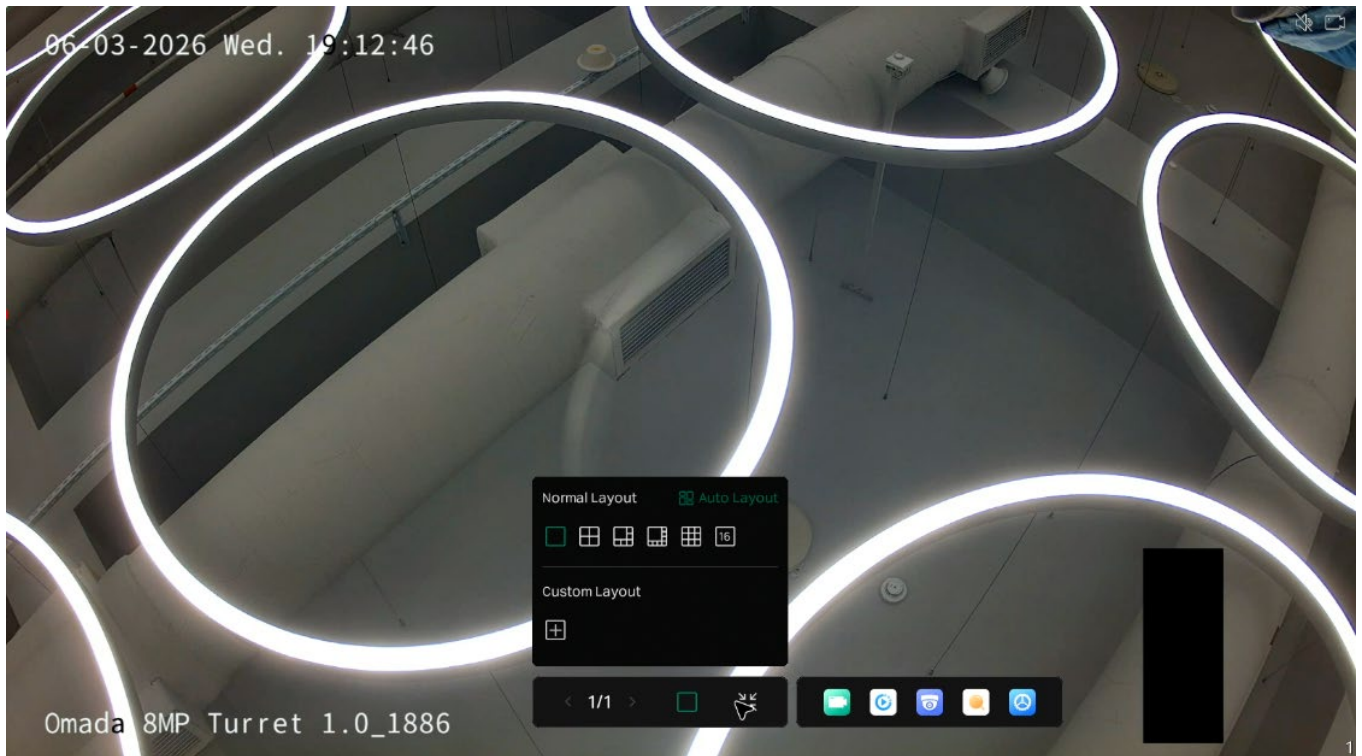

Click the corresponding buttons to change the number of displayed screens.

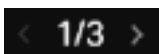

Click to jump to the previous/next page when the channels is more than the screens displayed in one page.



Click to exit/enter the full screen.

For the layout mode with multiple screens, you can change the location of a channel by clicking and dragging it to another location. To view a channel in the full screen, double click it. Double click it again to go back to multi-screen layout mode.

2.2 Configure Live View Settings via Toolbar

Select a channel in Live View to reveal the toolbar. Click the following icons to configure Live View settings, such as digital zoom, stream, and start an alarm.



Click to view the playback of this channel. Click **Playback for 5 minutes** to view instant playback. For detailed configuration, refer to [Playback](#).



Click to zoom in/out the live image.



(Microphone needed and only for certain cameras) Click the icon and then Start Talk to talk. With this function, your can talk to people in the monitor area in real time.



(Only for certain cameras) Click and use the slide bar to adjust the volume.



Displays the image resolution, HD or SD.



(Only for certain cameras) Click to manually start the alarm.



Hover your cursor to view the video information, including its channel, frame rate, bit rate, resolution, and encoding method.



Click to hide the toolbar.

3

Playback

This function allows you to play the history recordings, edit clips, and export clips. You can easily search the recordings based on the channel, date, and event. This chapter contains the following sections:

- [Instant Playback](#)
- [Play Normal Recordings](#)
- [Playback Recordings of Events](#)
- [Playback Operations](#)

NVR supports the following playback modes:

- **Instant Playback**

Play the video of a single channel recorded in the last five minutes.

- **Normal Playback**

Play the recordings of one day, including the continuous and motion event recordings.

- **Event Playback**

Play the recordings with events detected.

3.1 Instant Playback



You can replay the video recorded in the last five minutes via Instant Playback. Click a channel on Live View to reveal the toolbar. Click  and then **Playback for 5 minutes** to start instant playback.

3.2 Play Normal Recordings

Normal Recordings are video files from the continuous and event detection recordings. Follow the steps below to play normal recordings.

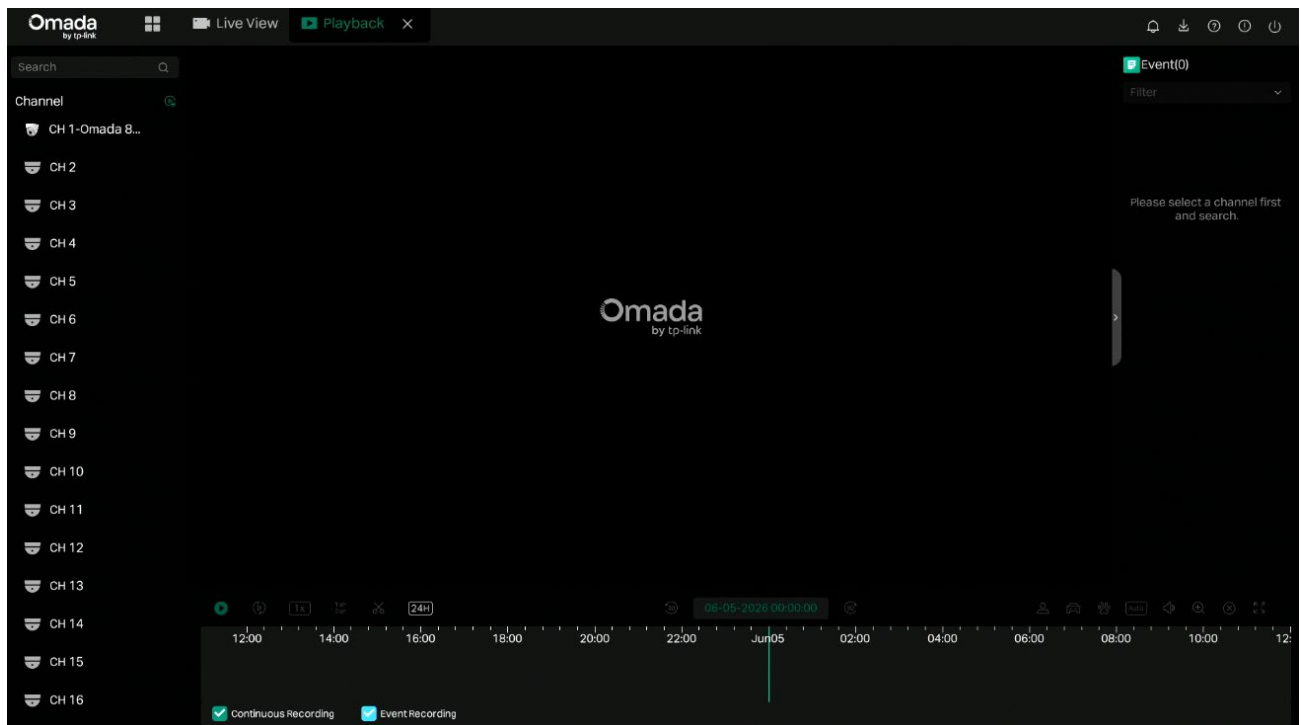
1. Click the  menu button on the upper left corner to open the menu. Click **Playback** to open the Playback module.



- On the left panel, select a channel to playback the recordings or click  to play channels in batch. The recording files are listed both on the time bar below. Click  to play the recordings.

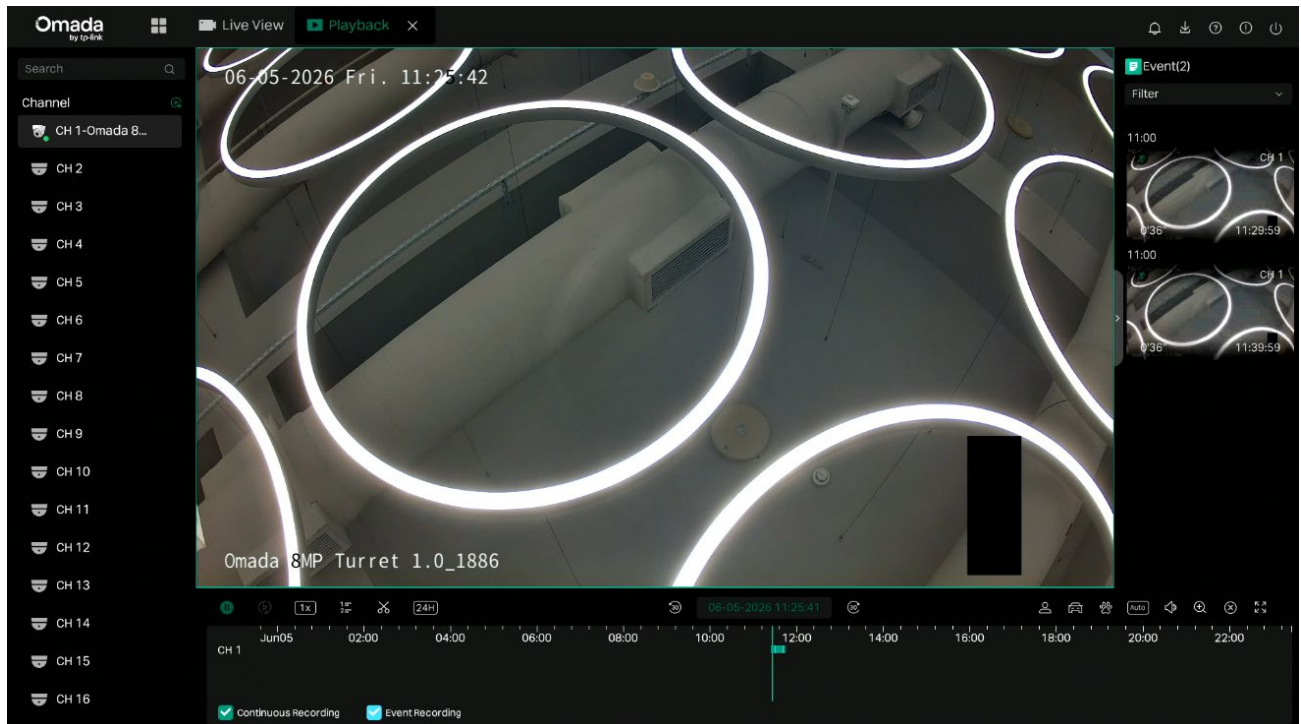

For more playback operations, refer to [Playback Operations](#).

3.3 Playback Recordings of Events

With Events configured, the NVR and cameras can detect and react to events. In Event Playback, you can search, play, and edit the videos recorded when certain events are detected, including human, vehicle, pet, line crossing, intrusion, motion, and tamper.

Note: If you have never configured Events on the NVR, there are no recordings of events. To configure Events, refer to [Events](#).

Follow the steps below to search and play the recordings of certain events.

1. Click the  menu button on the upper left corner to open the menu. Select a channel and click **Playback** to open the Playback module.

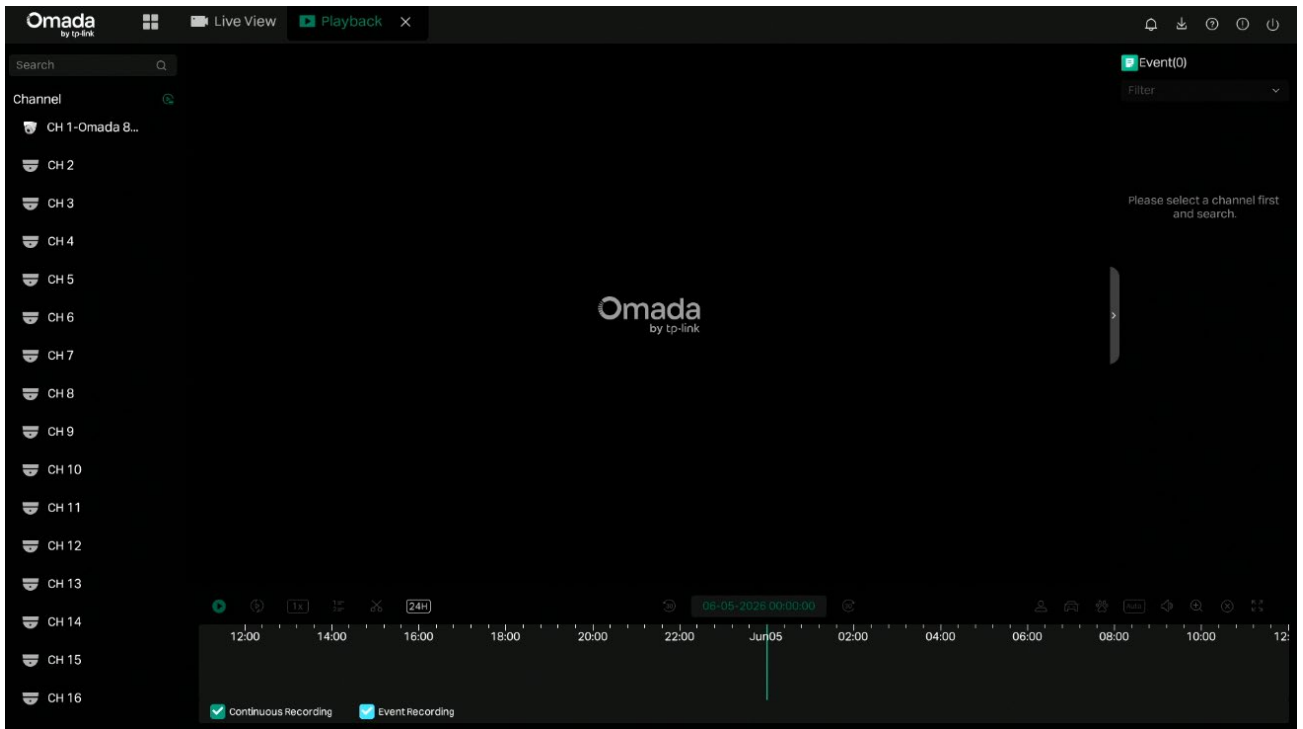

2. On the right panel, click **Filter**, select a time range, select a channel, select an event type from the drop-down list and click **Apply**. The recording files of events are listed on the right panel. Double click a recording in the list to play it.

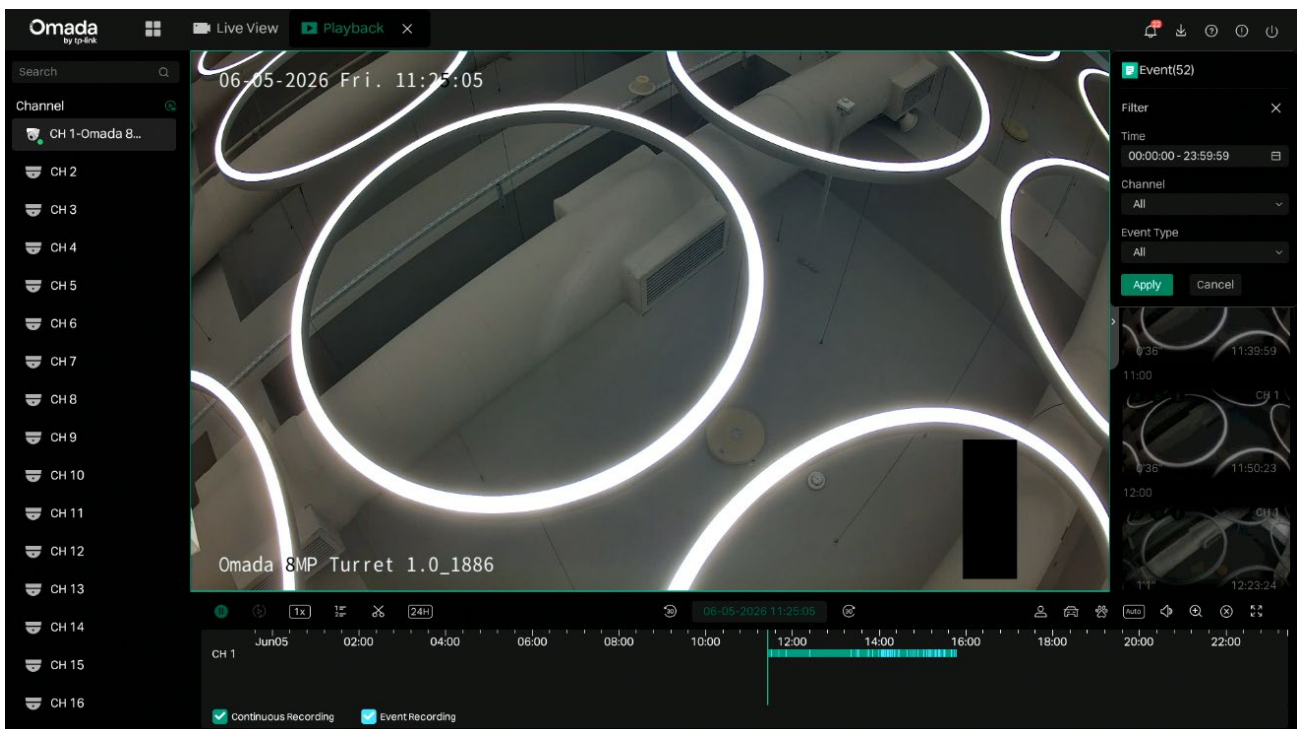















For more playback operations, refer to [Playback Operations](#).

3.4 Playback Operations

In the Playback module, you can use the icons and buttons in the toolbar and on the right panel to adjust the display, edit and back up the recordings.

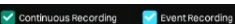

Note: The operations are not available in Instant Playback.

The following icons are supported when playing recordings:

	Click to play/pause the recording.
	Click to start frame-by-frame playback.
	Select from the drop-down list to change the playing speed.
	Enable Smart playback rules. By default, Play Event Recordings with 1x Playback Speed and play Non-event Recordings with 8x Playback Speed. You can change it as needed.
	Click to edit the recordings.
	Click to set the time span length.
	Jump forward/backward by 30 seconds.
	Click to play the human detection event recordings.
	Click to play the vehicle detection event recordings.
	Click to play the pet detection event recordings.
	Click to select the stream type for the single channel.
	Click and slide to adjust the volume.
	Zoom in or out via Digital Zoom..
	Click to clear all screens.
	Play the recordings in full screen.
	Select the recordings type .

3.4.1 Edit Recordings

Follow the steps below to clip video files.

1. Click  at the toolbar. Click  to set the beginning and end of the clip. Click the recordings again and drag the mouse to adjust the length of the clip.



2. After editing, you can click the **Export** button to export the clips.

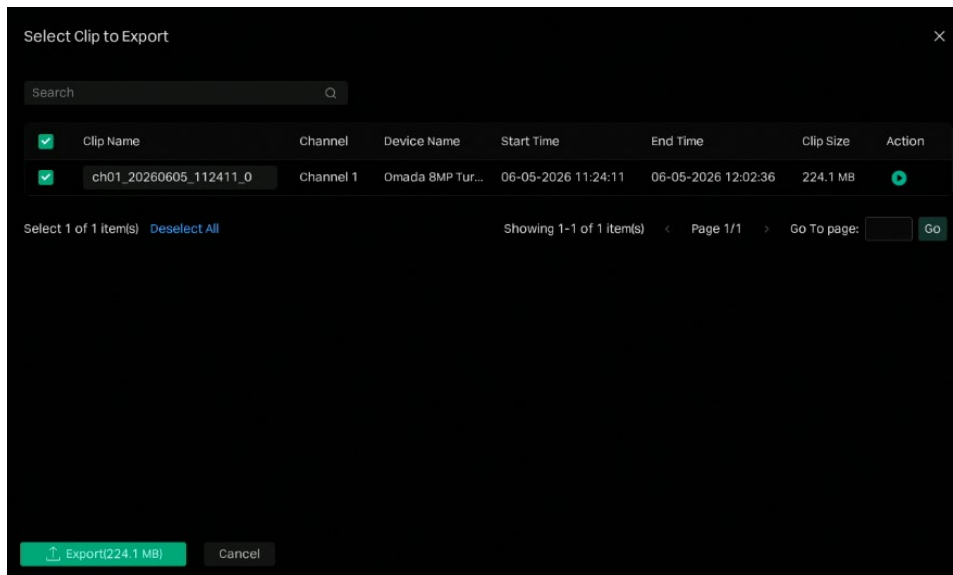

4

Configure Your Network Camera

This chapter introduces how to add your cameras to NVR and configure them. You can customize image effects and configure OSD (On Screen Display), Privacy Mask, and Stream, configure stream settings and events, etc,. This chapter contains the following sections:

- [Add Cameras to the NVR](#)
- [Plug and Play Settings](#)
- [Configure Image Effects](#)
- [Configure Stream Settings](#)
- [Events](#)
- [Smart](#)
- [Manage Your Cameras](#)

4.1 Add Cameras to the NVR

Omada NVR can add cameras singly, in batches or to a certain screen. You can also manually add cameras by entering their IP addresses and passwords. The processes vary depending on whether the camera has a password and whether Plug and Play is enabled. TP-Link security cameras have no passwords in default settings.

Choose one of the methods below and follow the steps to add your cameras:

- [Add Cameras Singly or in Batches](#)
- [Add a Camera to a Certain Screen](#)
- [Add Cameras Manually](#)

Connect cameras to the same network as the NVR. When adding Omada security cameras, the NVR will automatically modify the IP addresses to ensure every camera has a unique IP address and they are in the same subnet as your NVR. To add cameras from other brands, it is recommended to refer to their user guides before adding. If the cameras cannot be automatically found by the NVR, refer to [Add Cameras Manually](#).

4.1.1 Add Cameras Singly or in Batches

Add Uninitialized Cameras

- **When Plug and Play Enabled**

Note: After you connect the cameras to the network device, you will see a pop-up window in the Live View screen. Click **Add** to add the camera, and the camera's default IP address will be changed.

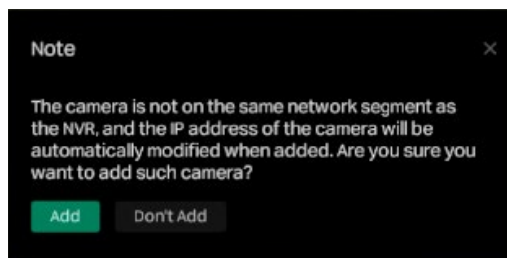

1. Click the  menu button on the upper left corner to open the menu. Click **Camera**.

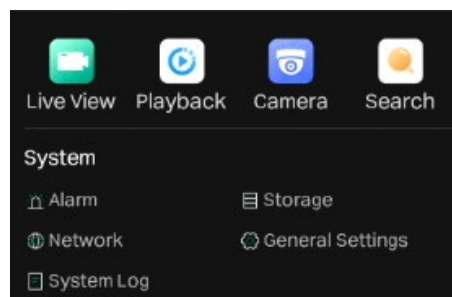

- Go to the **Devices Added** page, and you will see the device is added and initialized.

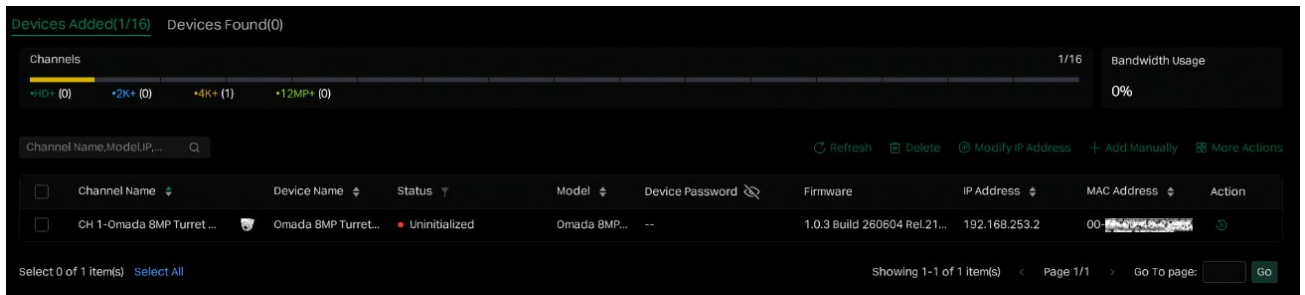

- If the status is "Uninitialized", click  and follow the web instructions to initialize the camera. After that, you will see the status is changed from "Uninitialized" to "Connected".

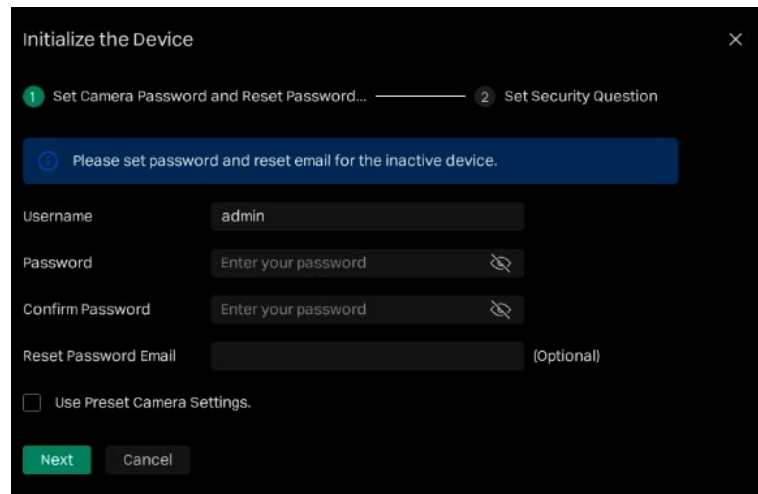

- After the cameras are added, you will see the status is changed from "Uninitialized" to "Connected".

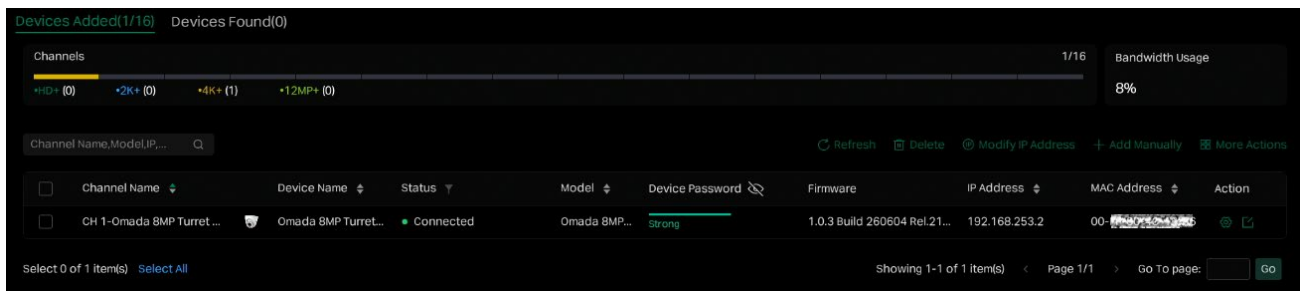

■ When Plug and Play Disabled

Follow the steps below to add the cameras.

- Click the  menu button on the upper left corner to open the menu. Click **Camera**.

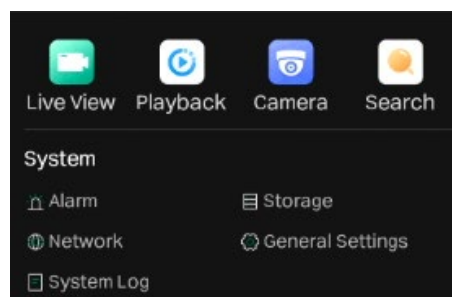

- Go to the **Devices Found** page, and click  to add a single camera. If you want to add cameras in batches, click the checkbox of cameras and click **Add in batches**.

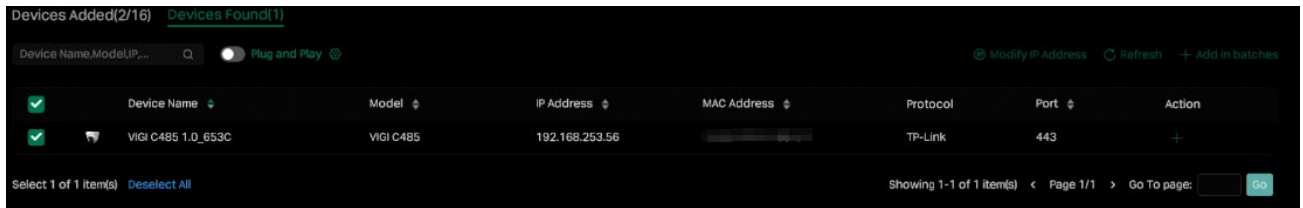

- Set a password for your cameras. Click **Next**. After the cameras are added, you can view the cameras in the **Device Added** list.

Initialize the Device

1 Set Camera Password and Reset Password... 2 Set Security Question

Please set password and reset email for the uninitialized device(s).

Username: admin

Password: Enter your password

Confirm Password: Enter your password

Reset Password Email: (Optional)

Use Preset Camera Settings.

Next Cancel

Add Initialized Cameras

- Click the  menu button on the upper left corner to open the menu. Click **Camera**.

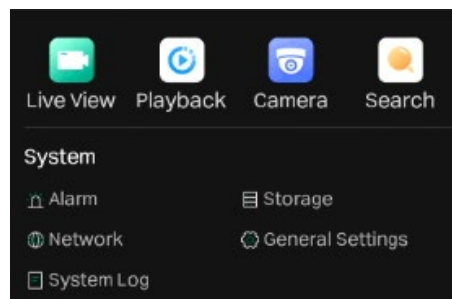

- Go to the **Devices Found** page, select the desired camera and click  to add. If you want to add cameras in batches, click the checkbox of cameras and click **Add in batches**.

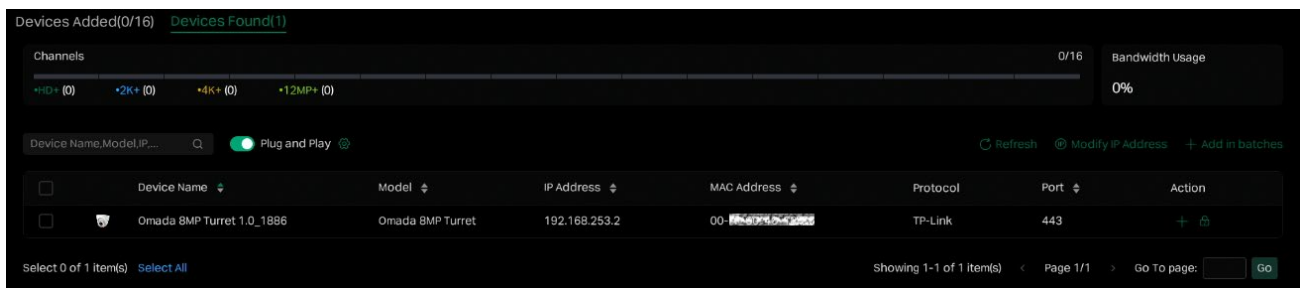

- If Plug and Play is disabled, you will need to enter the password manually and click **Confirm** to verify it.

Add Device [X]

To add your camera, please enter the camera's password.

Username: admin

Password: [] [Lock Icon]

[Confirm] [Cancel]

- If Plug and Play is enabled, the device will be directly added to the Devices Added page. The status is "Not certified". Click the Lock icon to enter the camera's password to verify it, and then the status will be changed to "Connected".

Devices Added(1/16) Devices Found(0)

Channels: +HD+ (1) +2K+ (0) +4K+ (0) +12MP+ (0) | 1/16 | Bandwidth Usage: 0%

Channel Name, Model, IP, ... [Search] [Refresh] [Delete] [Modify IP Address] [Add Manually] [More Actions]

Channel Name	Device Name	Status	Model	Device Password	Firmware	IP Address	MAC Address	Action
CH 1-Omada 8MP Turret...	Omada 8MP Turret...	Not certified	Omada 8MP...	--	--	192.168.253.206	00-80-00-00-00-00	[Lock] [Refresh] [Delete]

Select 0 of 1 item(s) Select All | Showing 1-1 of 1 item(s) | Page 1/1 | Go To page: [] Go

- After the cameras are added, you will see the cameras are in the Devices Added page.

Devices Added(1/16) Devices Found(0)

Channels: +HD+ (0) +2K+ (0) +4K+ (1) +12MP+ (0) | 1/16 | Bandwidth Usage: 8%

Channel Name, Model, IP, ... [Search] [Refresh] [Delete] [Modify IP Address] [Add Manually] [More Actions]

Channel Name	Device Name	Status	Model	Device Password	Firmware	IP Address	MAC Address	Action
CH 1-Omada 8MP Turret...	Omada 8MP Turret...	Connected	Omada 8MP...	Strong	1.0.3 Build 260604 Rel21...	192.168.253.2	00-80-00-00-00-00	[Lock] [Refresh] [Delete]

Select 0 of 1 item(s) Select All | Showing 1-1 of 1 item(s) | Page 1/1 | Go To page: [] Go

4.1.2 Add a Camera to a Certain Screen

You can add a camera to a certain channel in the Live View screen. Follow the steps below to finish the configuration.

1. Click a screen in the Live View screen and click + on the bottom left corner.



2. Choose **Auto Discover** or **Add Manually**.

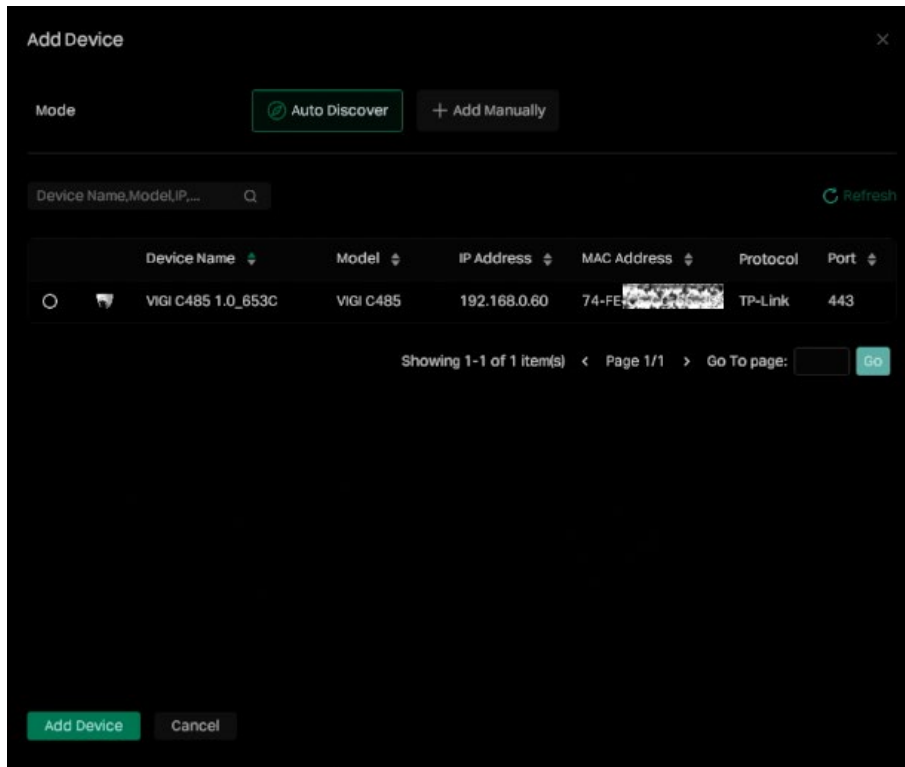

3. Follow the web instructions to add the camera to this screen.

4. 1. 3 Add Cameras Manually

If the devices cannot be automatically found by the NVR, you can add cameras manually using its information. Follow the steps below to finish the configuration.

1. Click the  menu button on the upper left corner to open the menu. Click **Camera**.

- Click **Add Manually**, and enter the information of the camera to add it. Enter the IP address and password. Click **Confirm**.

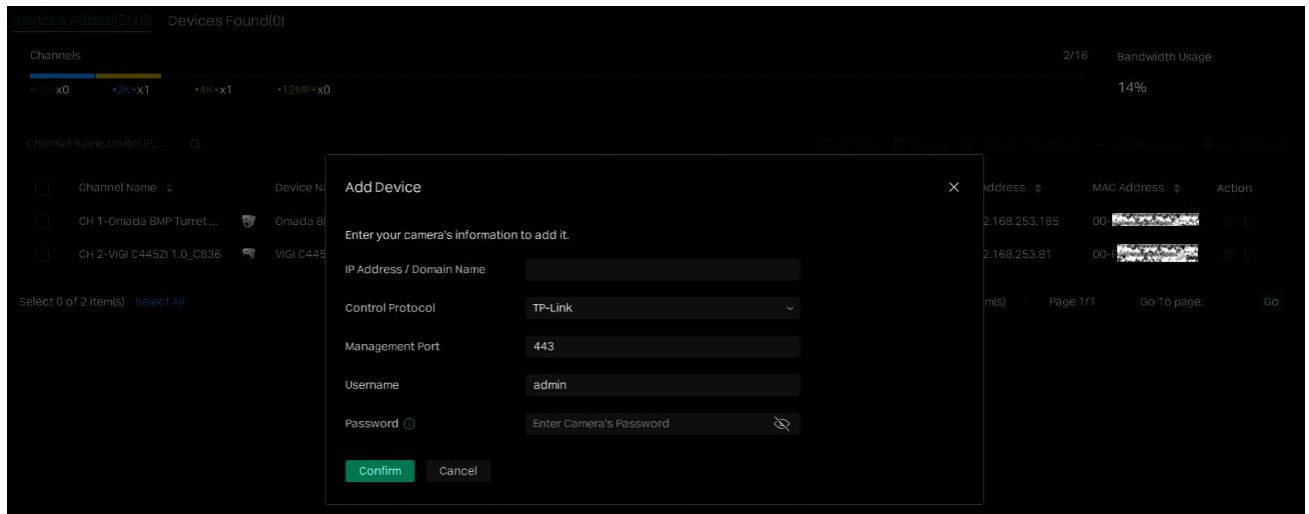

IP Address/ Domain Name

The IP address/Domain Name of the camera.

Control Protocol

Select a protocol that your camera supports. The global protocol that allows surveillance and security devices from different manufacturers to operate together seamlessly.

Management Port

The management port to configure, maintain, and support a network device.

Username

The username of the camera.

Password

Enter the password of the camera.

4.1.4 Modify IP Addresses of Cameras

To avoid IP conflict and make sure your cameras are in the same subnet, you can modify the IP addresses manually. Follow the steps below to finish the configuration.

- Click the  menu button on the upper left corner to open the menu. Click **Camera**.
- Click the checkbox of camera(s) and click **Modify IP Address**. You can select multiple cameras to modify their IP addresses in batches.

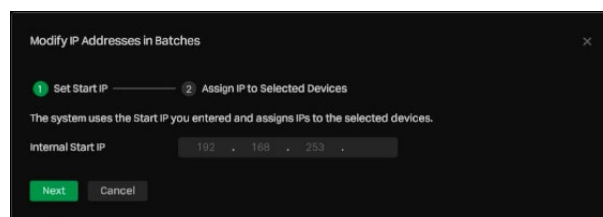



- Set the starting IP address you assigned for the camera(s). Click **Next**.

- Click **Confirm** to confirm the new IP address(es).

Note: The IP address(es) will be assigned to camera(s) in order.

4.2 Plug and Play Settings

Plug and Play function enables NVR to automatically find and add cameras. You can enable or disable this function according to your needs. To configure and view the settings, click the  menu button on the upper left corner to open the menu. Click **Camera**, go to **Camera > Devices Found**, and click the  button beside **Plug and Play**.

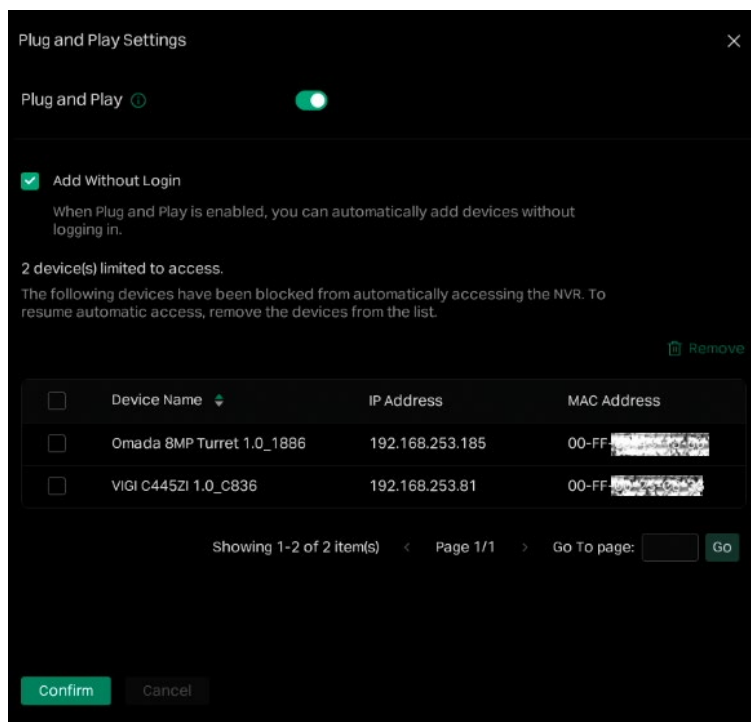

■ Add Without Login

When the cameras and your NVR are in the same network, the cameras will be automatically added without your account logged in.

■ Devices Limited to Access

After the cameras are added to the NVR, they will be automatically added to the list, which means they cannot be added to the NVR again automatically. If you want to automatically add the cameras for the second time, remove the cameras from the devices limited access list.

4.3 Configure Image Effects

To adjust the image effect, you can configure the image settings, OSD settings and privacy masks.

4.3.1 Configure Image Settings

- Click the  menu button on the upper left corner to open the menu. Click **Camera**.

- Go to **Devices Added** page. Click the  icon in the Action column of the desired camera. Go to **Display > Image**, and configure the following parameters.

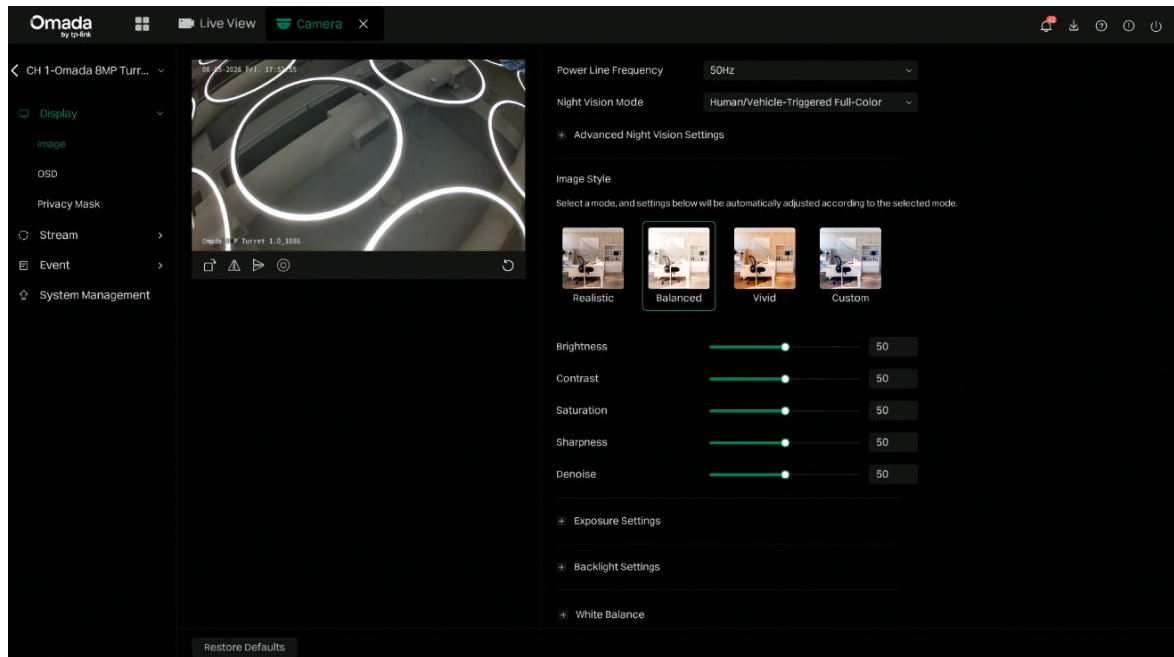

Click the corresponding icon to adjust the image direction.

General Settings

Power Line Frequency

Set the Power line frequency consistent with local utility settings to eliminate image flickering associated with fluorescent lights.

Night Vision Mode

Human/Vehicle Triggered Full-Color: The camera switches to the full-color mode once it detects a person or vehicle.

Auto Color: The camera turns on or off the white supplement light according to the light condition of the environment.

Auto IR: The camera turns on or off the IR supplement light according to the light condition of the environment.

White LED Always On: White supplement light is on.

IR Always On: IR supplement light is on.

Off: Supplement light is off.

Custom: Select it to configure Day/Night Switch and illuminator.

Advanced Night Vision Settings

Day/Night Switch Sensitivity

Specify the sensitivity to switch the image settings of day and night. The switch is easier to be triggered when the sensitivity decreases.

Delayed Switch	Decide how long the camera waits to enable or disable the infrared light when the environment reaches the light condition.
White Light Intensity	<p>Auto: The camera automatically controls the brightness of the white light.</p> <p>Manual: You can drag the Level bar below to manually control the brightness of the white light.</p>
Infrared Light Intensity	<p>Auto: The camera automatically controls the brightness of the infrared light.</p> <p>Manual: You can drag the Level bar below to manually control the brightness of the infrared light.</p>
Always Full-Color at Live View	When enabled, the camera will automatically turn on Full-Color Night Vision when you stream Live Video.
Image Style	
Image Style	Select a display mode — Realistic, Balanced, Vivid, or Custom. The settings below will automatically adjust based on your selection.
Brightness	Increasing the value will lighten the image.
Contrast	Increasing the value will increase the difference between the brighter and darker parts.
Saturation	Increasing the value will enrich the color of the image.
Sharpness	Increasing the value will sharpen the image.
Denoise	Increasing the value will make the image clearer and the less noise it will have. However, for fast-moving objects, an excessively high value may result in slight motion blur.
Exposure Settings	
Exposure	<p>Select the exposure mode as needed.</p> <p>Auto: The camera adjusts the exposure automatically.</p> <p>Manual: The image exposure is fixed. If you select Manual, adjust the slide bar of Gain to specify its value, and select a shutter speed. Higher gain and slower shutter speed result in brighter images.</p> <p>Low Motion Blur: Low motion blur occurs when a moving object is captured over a longer exposure time, resulting in a streaked or blurred image.</p>
Anti-flicker	This function minimizes influences caused by flickering.
Backlight Settings	

BLC Area	<p>BLC (Backlight Compensation) optimizes the camera to increase light exposure for darkened areas and helps you to see details more clearly.</p> <p>Select an area to compensate light.</p> <p>If you select Custom, draw a green rectangle on the live view image as the BLC area.</p>
WDR	<p>WDR (Wide Dynamic Range) can improve the image quality under high-contrast lighting conditions where both dimly and brightly lit areas are present in the field of view.</p> <p>If you select On, the camera balances the light of the brightest and darkest areas automatically. You may set the gain value, or the sensor's sensitivity, manually.</p>
White Balance	
White Balance	<p>White balance is a process of removing unrealistic color casts, so that objects which appear white in person are rendered white in the image.</p> <p>Auto: The camera adjusts the color temperature automatically.</p> <p>Locked: The camera keeps the current color settings all the time.</p> <p>Daylight/Natural Light/Incandescent/Warm Light: The camera adjusts the color temperature to remove the color casts caused by the corresponding light.</p> <p>Custom: Drag the slide bar to configure the color temperature, and the camera keeps the settings all the time. The higher the value is, the more intense the red/blue color is.</p>
Restore Defaults	Click to restore to factory default settings.

4.3.2 Configure OSD Setting

You can configure OSD (On Screen Display) to edit the information displayed in Live View and recordings. Follow the steps below to configure OSD.

1. Click the  menu button on the upper left corner to open the menu. Click **Camera**.

- Go to **Devices Added** page. Click the  icon in the Action column of the desired camera. Go to **Display > OSD**, configure the following parameters, then click **Apply**.

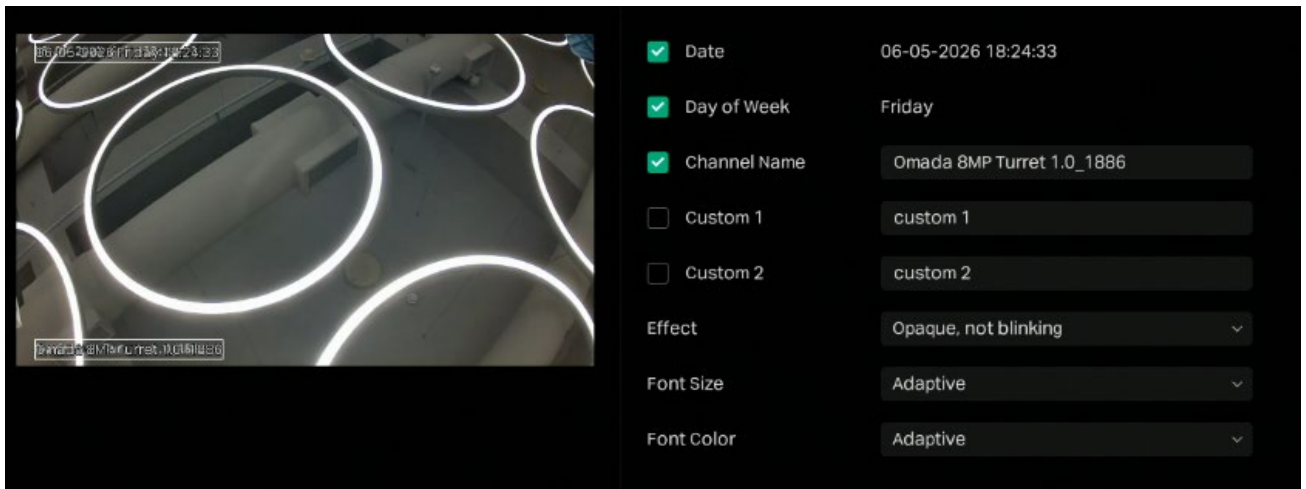



Note: If you change **Channel Name** in the OSD setting, you also change the camera name.

Date	Check to display the date on the image.
Day of Week	Check to display the week on the image.
Channel Name	Check to display the channel name on the image. You can also check Custom and specify a text to display.
Effect	Set the blinking display effect of the OSD.
Font Size	Set the font size or select Adaptive to adjust the size based on the image.
Font Color	Set the font color or select Adaptive to adjust the color based on the image.
Restore Defaults	Click to restore to factory default settings.

4.3.3 Configure Privacy Mask

With Privacy Mask, you can set privacy area in the image. The area cannot be recorded and monitored.

Follow the steps below to configure Privacy Mask.

- Click the  menu button on the upper left corner to open the menu. Click **Camera**.
- Go to **Devices Added** page. Click the  icon in the Action column of the desired camera. Go to **Display > Privacy Mask**. Draw the privacy areas on the preview screen (the green squares in the picture below), you can select to use a solid type or mosaic type. Use the mouse to adjust the size

and location of areas. To remove a certain privacy area, select it and click **Delete**. To remove all privacy areas, click **Clear All**. Click **Apply** to finish the configuration.

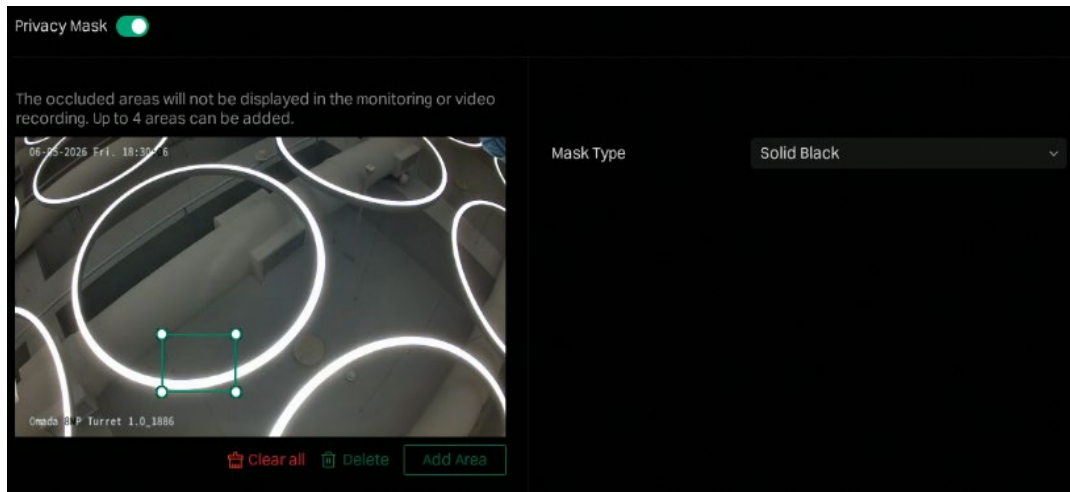

4.4 Configure Stream Settings

In Stream Settings, you can configure video stream levels. Video stream levels decide the video quality.

4.4.1 Configure Videos

The NVR supports two stream levels, main stream and substream. In Live View, the NVR decides which stream is applied to the channels automatically based on network bandwidth and device performance. In Recording Controls, you can apply them to the channels to record with different stream settings. After configuring the streams, refer to Recording Controls to apply them to recordings.

Follow the steps below to configure the stream settings.

1. Click the  menu button on the upper left corner to open the menu. Click **Camera**.

2. Go to **Devices Added** page. Click the  icon in the Action column of the desired camera. Go to **Stream > Videos**, and select the stream type, then configure the following parameters. Click **Apply**.

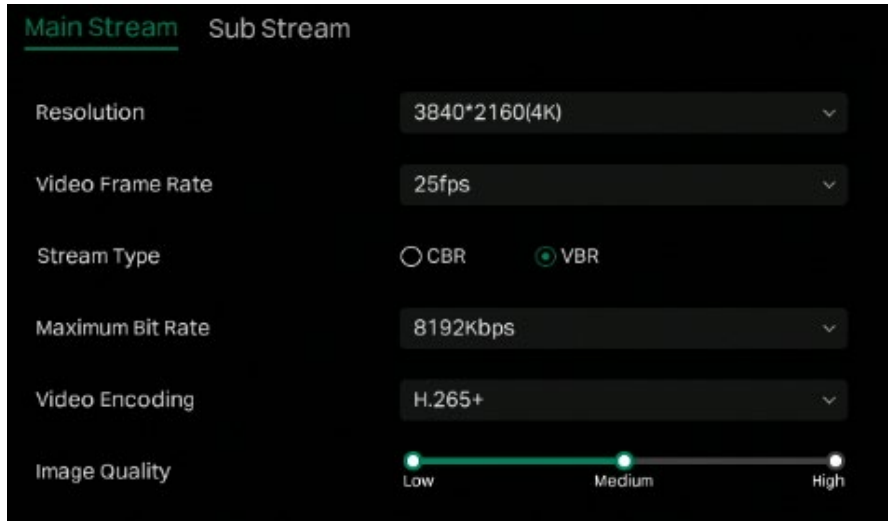

The screenshot shows a configuration panel for a video stream. It has two tabs: 'Main Stream' (selected) and 'Sub Stream'. The settings are as follows:

- Resolution:** 3840*2160(4K)
- Video Frame Rate:** 25fps
- Stream Type:** CBR (unselected), VBR (selected)
- Maximum Bit Rate:** 8192Kbps
- Video Encoding:** H.265+
- Image Quality:** A slider ranging from Low to High, currently positioned at Medium.

Resolution Specify the resolution of the video stream. The screen displays images more clearly when the resolution increases.

Video Frame Rate Specify the frame rate of videos. The video is more fluent when the rate increases.

Stream Type Select a type of bit rate.

VBR: The bit rate changes with the image within Maximum Bit Rate.

CBR: The bit rate is Maximum Bit Rate all the time.

Maximum Bit Rate When VBR selected as the bit rate type, specify the upper limit of bit rate.

When CBR selected as the bit rate type, specify the bit rate.

Video Encoding

Video encoding format determines how video data is compressed for transmission and storage.

H.264: Delivers good image quality at moderate file sizes, compatible with nearly all video management systems and devices.

H.264+: Further reduces bandwidth and storage requirements, especially in static scenes, without significantly lowering image quality.

H.265: Provides similar video quality as H.264 but at roughly 50% lower bit rates, making it ideal for saving bandwidth and storage, especially for high-resolution video like 4K.

H.265+: Achieves even greater bandwidth and storage savings by intelligently compressing static areas of the video while preserving detail in moving objects.

Note: H.265 and H.265+ require more processing power for decoding. Ensure your hardware or software systems support the chosen codec.



Image Quality

When VBR selected as the bit rate type, set the image quality as high, medium, or low.

- (Optional) If you also want to apply the stream settings to other channels, click **Copy to other devices** and select the channels. You can click **Restore Defaults** to restore to factory default settings.

4.4.2 Configure Audio

In Audio, you can configure the audio output and input settings.

- Click the  menu button on the upper left corner to open the menu. Click **Camera**.
- Go to **Devices Added** page. Click the  icon in the Action column of the desired camera. Go to **Stream > Audio**, and configure the following parameters. Click **Apply**.

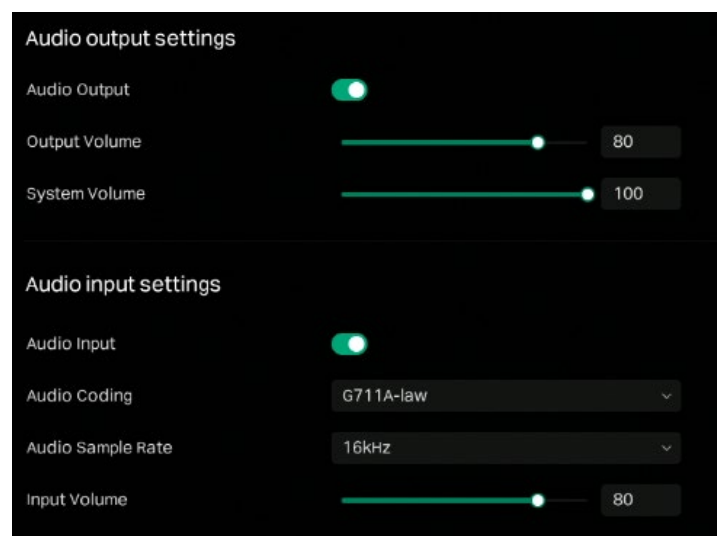

Audio Output



Toggle on to allow the camera to deliver sound.

Output Volume	Adjust the volume of the speaker.
System Volume	Adjust the volume of the sound alarm.
Audio Input	Toggle on to turn on the camera's microphone.
Audio Coding	Select the encoding type of the audio.
Audio Sample Rate	Sampling number per second. The higher the sample rate (e.g., 16kHz is higher than 8kHz), the more samples will be in a second, the richer the sound details captured, and the clearer the sound quality.
Input Volume	Adjust the volume of the microphone.

- (Optional) If you also want to apply the audio settings to other channels, click **Copy to other devices** and select the channels. You can click **Restore Defaults** to restore to factory default settings.

4.4.3 Configure SRTP Settings

If you enable SRTP, the video data will be encrypted and you may be unable to play the video using the third-party clients or NVRs. To use this feature, the camera also should support SRTP.

- Click the  menu button on the upper left corner to open the menu. Click **Camera**.
- Go to **Devices Added** page. Click the  icon in the Action column of the desired camera. Go to **Stream > Advanced Settings**, and enable SRTP. Click **Apply**.

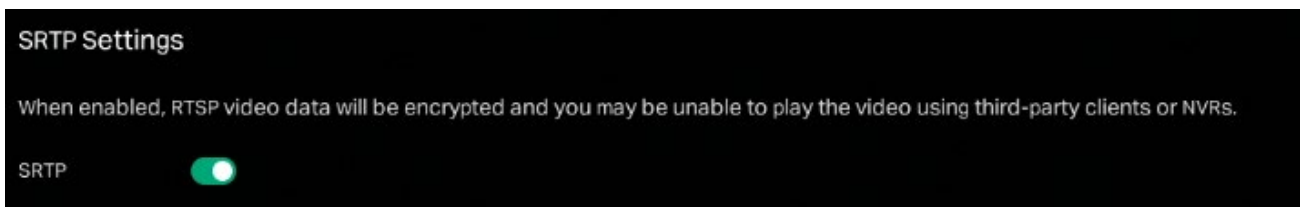



- (Optional) If you also want to apply the settings to other channels, click **Copy to other devices** and select the channels.

4.5 Events

This section guides you on how to configure the event settings and alarm actions when your cameras detect different types of events. The NVR monitors the user-defined areas and you'll be automatically alerted to any suspicious activity in your home and office.

4.5.1 Alarm Schedule and Triggered Action

Alarm schedule determines when a camera's event detection, recording, or other event-based features are active. It allows you to automate when the camera is actively monitoring and recording, based on a predefined schedule. Triggered actions are the responses to the detected incidents or targets during the scheduled time. This configuration is optional.

1. Click the  menu button on the upper left corner to open the menu. Click **Camera**.
2. Go to **Devices Added** page. Click the  icon in the Action column of the desired camera. Go to **Event**, then go to the desired event detection type page.
3. Click **Alarm Schedule** tab.

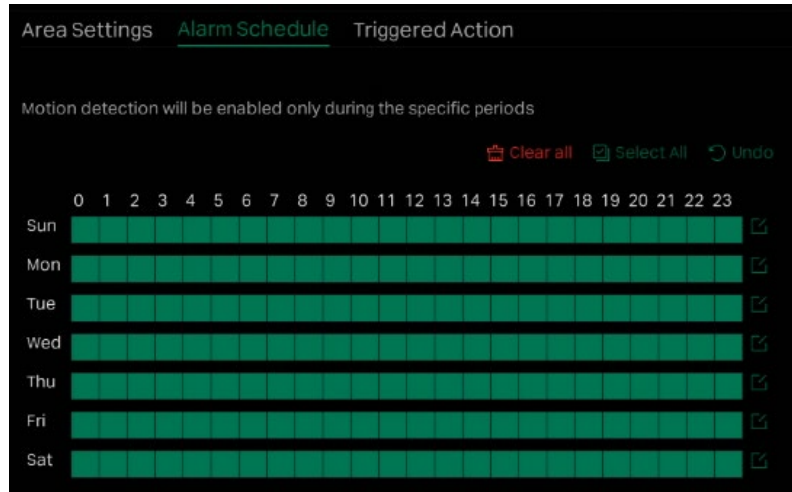

4. Drag the time bar to draw desired valid time.

Note:

- Each cell represents one hour.
 - The default setting is 24/7.
 - Up to 24 time periods can be configured for a day.
5. Click the edit icon to edit the time. You can copy a schedule for a day to any other days. In the pop-up window, select the days of the week where you need to copy the time.

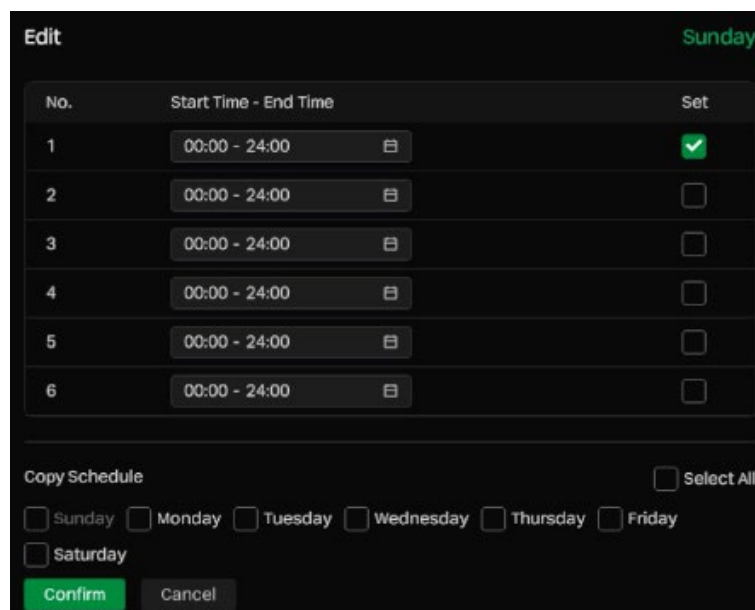

6. Click **Triggered Action** tab to select the actions.

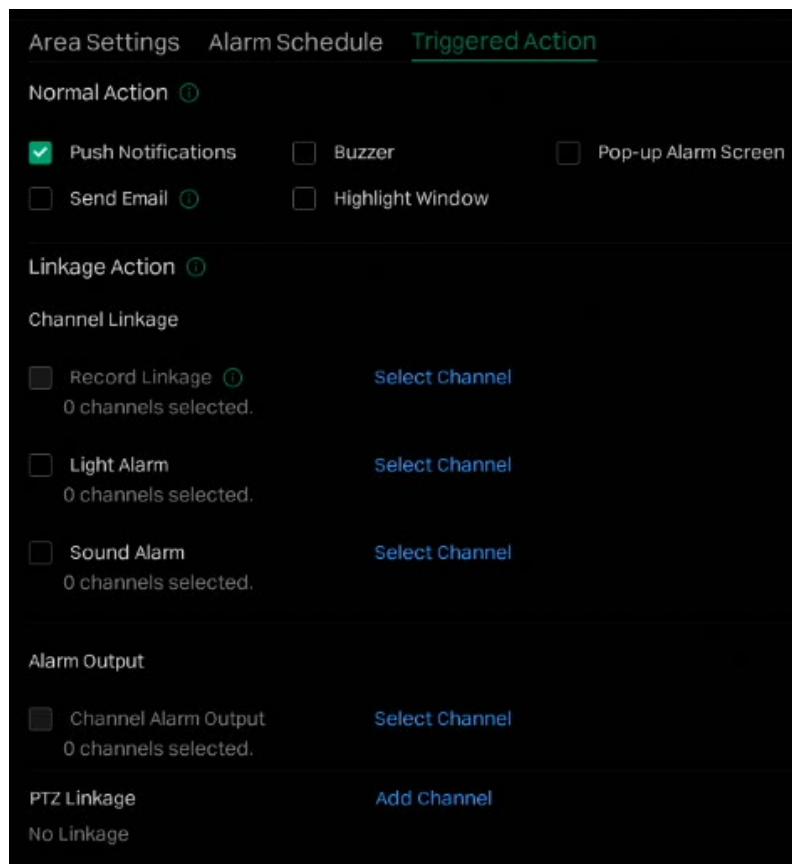



Push Notifications	The system will push notifications when an event is triggered.
Buzzer	The buzzer on the NVR will beep when an event is triggered.
Pop-up Alarm Screen	The channel in Live View will be in full screen when an event is triggered.
Send Email	The system will send an email when an event is triggered.
Highlight Window	The live view window will be highlighted when an event is triggered.
Recording Linkage	The channels you select for recording linkage will start recording when the current channel detects an event.
Light Alarm	(Only supports camera models with light alarm) The camera will trigger light alarm when cameras detect an event.
Sound Alarm	(Only supports camera models with audible alarm) The buzzer on the camera will alarm when cameras detect an event.

Alarm Output	(Only supports camera models with audible alarm) The connected alarm output device will sound when cameras detect an event.
PTZ Linkage	(Only supports PTZ cameras) The camera will execute Preset or Patrols when cameras detect an event.

- Click **Apply**. If you also want to apply the settings to other channels, click **Copy to other devices** and select the channels. You can click **Restore Defaults** to restore to factory default settings.

4.5.2 Motion Detection

Motion detection allows cameras to detect the moving objects in the monitored area and triggers alarm actions. You can customize the motion detection settings, set the alarm schedule, and select the triggered actions. Follow the steps below to finish the configuration.

- Click the  menu button on the upper left corner to open the menu. Click **Camera**.
- Go to **Devices Added** page. Click the  icon in the Action column of the desired camera. Go to **Event > Motion Detection**. Enable **Motion Detection**.

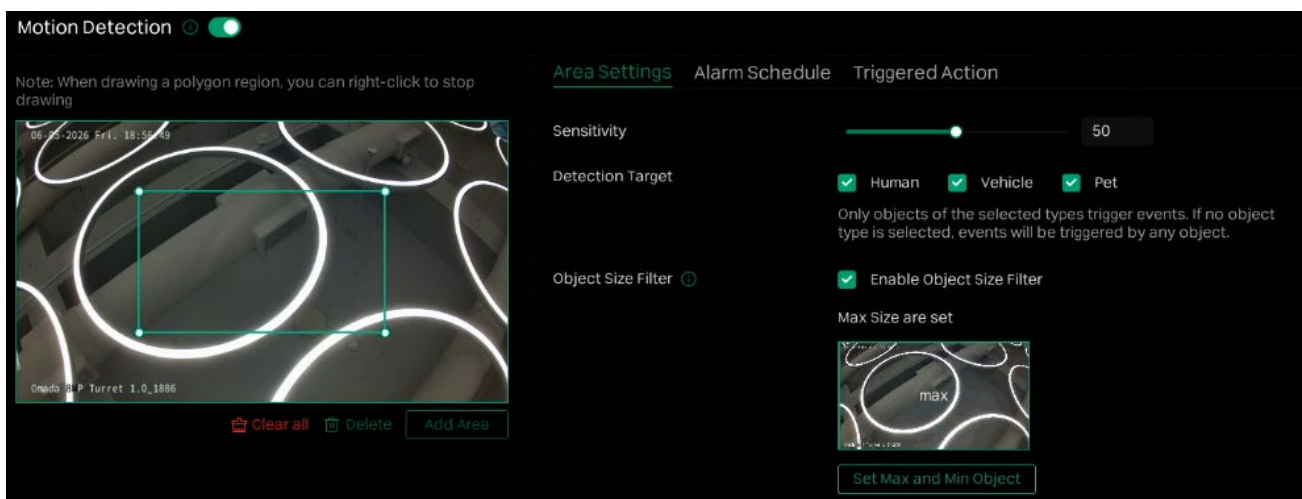

- Click **Add Area** to draw an area for motion detection on the preview screen. The whole screen is selected by default. You may drag the corners to change the shape of the area and drag the whole area to move it. You may delete a selected area, clear all areas, expand the selected areas to the full screen, or add another area. Then configure the motion detection settings. You can manually draw an area by clicking the mouse on the image. Right-click to end drawing, click the midpoint of a line segment to add an endpoint, double-click an endpoint to delete it, and you can draw up to 16 polygons.

Note: You may draw up to four areas and need to configure settings for each area.

Sensitivity	Drag the slide bar to adjust the value. The higher the value is, the easier it is to trigger an alarm.
Detection Target	Select the target type, human, vehicle or pet. Only objects of the selected types trigger events. If no object type is selected, events will be triggered by any object.



Object Size Filter

Click **Set Max and Min Object** to define the smallest and largest object sizes that will trigger events.

4. Refer to [Alarm Schedule and Triggered Action](#) for settings if needed.
5. Click **Apply**. If you also want to apply the settings to other channels, click **Copy to other devices** and select the channels. You can click **Restore Defaults** to restore to factory default settings.

4.5.3 Line Crossing Detection

Line crossing detection triggers alarm actions when cameras detect that moving objects cross a customized virtual line. You can customize the line crossing detection settings, select the triggered actions and set the alarm schedule. Follow the steps below to finish the configuration.

1. Click the  menu button on the upper left corner to open the menu. Click **Camera**.
2. Go to **Devices Added** page. Click the  icon in the Action column of the desired camera. Go to **Event > Line Crossing Detection**. Enable **Line Crossing Detection**.

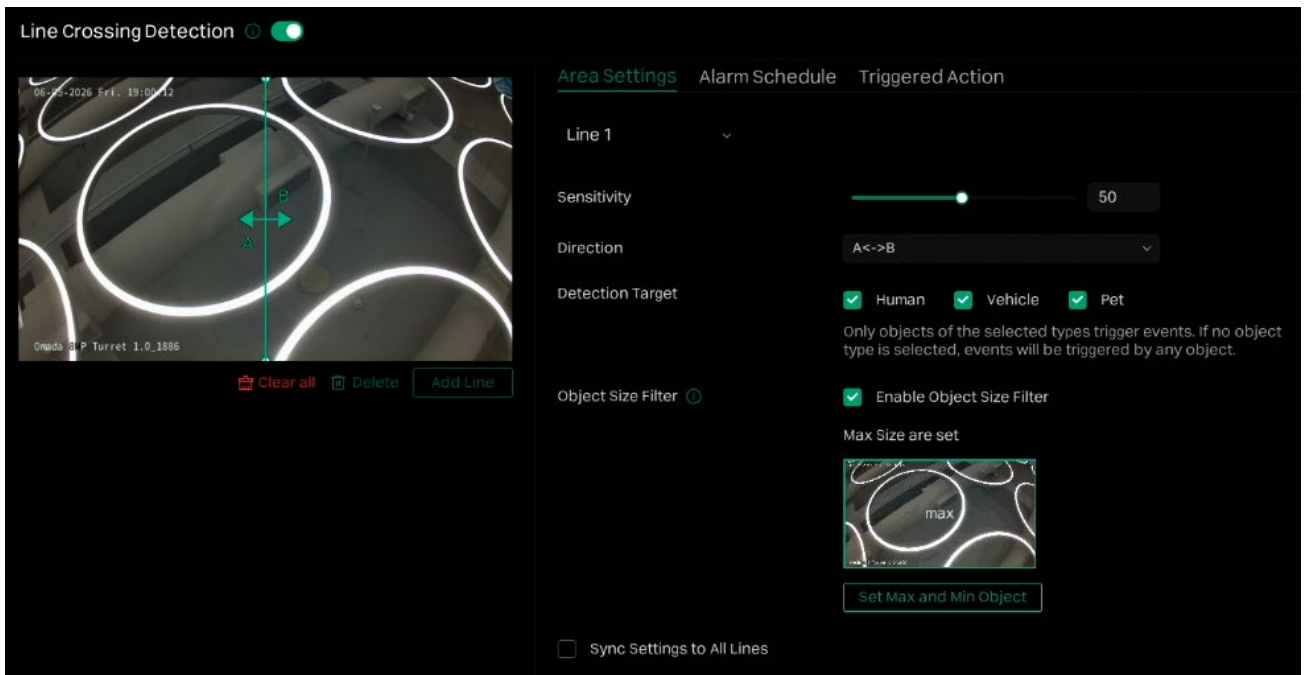

3. Draw lines on the preview screen. Select the line and configure settings of line crossing detection. You can check **Sync Settings to All Lines**.

Sensitivity

The higher the value is, the easier it is to detect a target that crosses the line.

Direction	<p>Choose the direction from which the target crosses the line.</p> <p>A->B: Only the target crossing the configured line from the A side to the B side can be detected.</p> <p>B->A: Only the target crossing the configured line from the B side to the A side can be detected.</p> <p>A<->B: The target going across the line from both sides can be detected and alarms are triggered.</p>
Detection Target	<p>Select the target type, human, vehicle or pet. Only objects of the selected types trigger events. If no object type is selected, events will be triggered by any object.</p>
Object Size Filter	<p>Click Set Max and Min Object to define the smallest and largest object sizes that will trigger events.</p>

4. Refer to [Alarm Schedule and Triggered Action](#) for settings if needed.
5. Click **Apply**. If you also want to apply the settings to other channels, click **Copy to other devices** and select the channels. You can click **Restore Defaults** to restore to factory default settings.

4.5.4 Intrusion Detection

Area intrusion triggers alarm actions when the NVR detects an intrusion in the specified areas. You can customize the area intrusion settings, select the triggered actions and set the alarm schedule. Follow the steps below to finish the configuration.

1. Click the  menu button on the upper left corner to open the menu. Click **Camera**.

- Go to **Devices Added** page. Click the  icon in the Action column of the desired camera. Go to **Event > Intrusion Detection**. Enable **Intrusion Detection**.

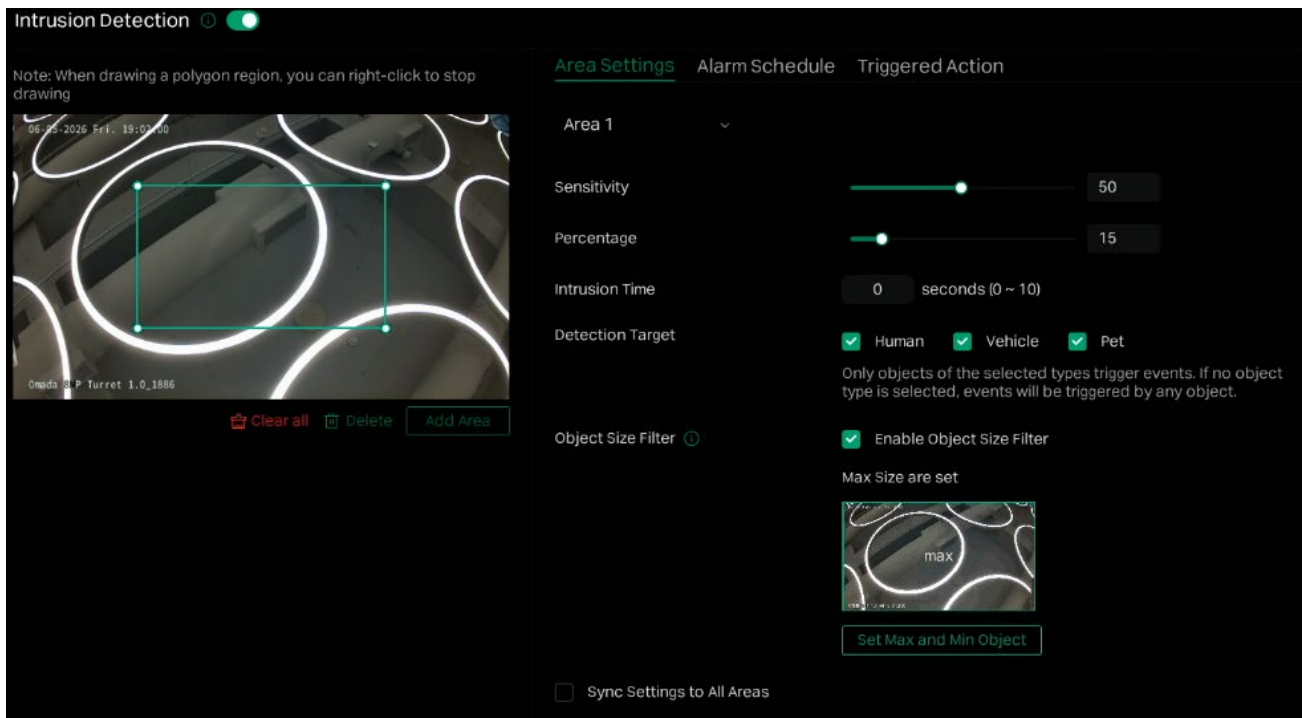

- Click **Add Area** to draw an area for intrusion detection on the preview screen. The whole screen is selected by default. You may drag the corners to change the shape of the area and drag the whole area to move it. You may delete a selected area, clear all areas, expand the selected areas to the full screen, or add another area. Then configure the motion detection settings. You can manually draw an area by clicking the mouse on the image. Right-click to end drawing, click the midpoint of a line segment to add an endpoint, double-click an endpoint to delete it, and you can draw up to 16 polygons.

Note: You may draw up to four areas and need to configure settings for each area. You can check **Sync Settings to All Areas**.



Sensitivity	The higher the value is, the more easily an intrusion action can be detected.
Percentage	Set the percentage of intrusion detection. When an object takes up the specific percentage of the area, the alarm actions will be triggered.
Intrusion Time	Intrusion time stands for the threshold a target loiters in the area. Any stay longer than the intrusion time will trigger the linkage action.
Detection Target	Select the target type, human, vehicle or pet. Only objects of the selected types trigger events. If no object type is selected, events will be triggered by any object.
Object Size Filter	Click Set Max and Min Object to define the smallest and largest object sizes that will trigger events.

- Refer to [Alarm Schedule and Triggered Action](#) for settings if needed.

- Click **Apply**. If you also want to apply the settings to other channels, click **Copy to other devices** and select the channels. You can click **Restore Defaults** to restore to factory default settings.

4.5.5 Camera Tampering

Camera tampering triggers alarm actions when an area of camera's lens is purposely blocked, obstructed or vandalized. You can customize the video tampering settings, select the triggered actions and set the alarm schedule for cameras. Follow the steps below to finish the configuration.

- Click the  menu button on the upper left corner to open the menu. Click **Camera**.
- Go to **Devices Added** page. Click the  icon in the Action column of the desired camera. Go to **Event > Tamper Detection**. Enable **Tamper Detection**.

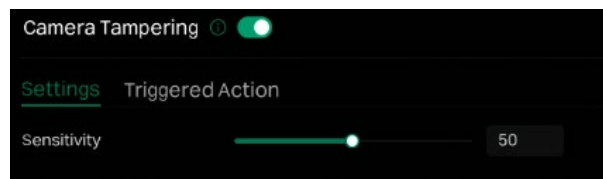

- Set the sensitivity of camera tampering. A higher value can trigger the alarm actions more easily
- Configure triggered actions if needed.

Push Notifications	The system will push notifications when an event is triggered.
Buzzer	The buzzer on the NVR will beep when an event is triggered.
Pop-up Alarm Screen	The channel in Live View will be in full screen when an event is triggered.
Send Email	The system will send an email when an event is triggered.
Highlight Window	The live view window will be highlighted when an event is triggered.
Recording Linkage	The channels you select for recording linkage will start recording when the current channel detects an event.
Light Alarm	(Only supports camera models with light alarm) The camera will trigger light alarm when cameras detect an event.
Sound Alarm	(Only supports camera models with audible alarm) The buzzer on the camera will alarm when cameras detect an event.



- Click **Apply**. If you also want to apply the settings to other channels, click **Copy to other devices** and select the channels. You can click **Restore Defaults** to restore to factory default settings.

4.6 Manage Your Cameras

For an added camera, you can manage its name, network configurations, account, firmware, and restart time, or just remove it.

4.6.1 Modify Camera Connection Parameters

Note: The cameras should be in the connected status.

1. Click the  menu button on the upper left corner to open the menu. Click **Camera**.
2. Go to **Devices Added** page. Click the  icon in the Action column of the desired camera, and modify the name. Click **Save**.

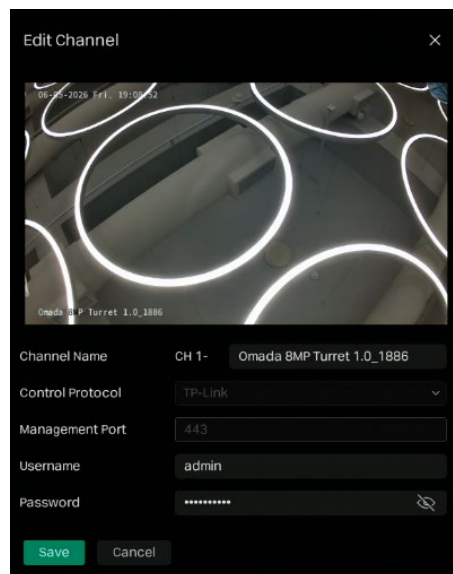

Channel Name	Specify the camera name.
Control Protocol	Display the protocol used to control the camera.
Management Port	Specify the management port.
Username	Displays the login name of the camera.
Password	You can view the login password of the camera after verifying the NVR password.

4.6.2 Change the Password and Reset Email

You can change the device password to enhance the security.

1. Click the  menu button on the upper left corner to open the menu. Click **Camera**.

- Go to **Devices Added** page. Select the desired camera and click the **More Actions** button, then click **Change Password**. Verify the NVR password and then enter the new settings and Click **Save**.

Change Password [X]

1 Set Camera Password and Reset Password... ————— 2 Set Security Question

Please set password and reset email for the selected devices.

Username: admin

Password: Enter your password [Eye Icon]

Confirm Password: Enter your password [Eye Icon]

Reset Password Email: [Optional]

Use Preset Camera Settings.

Next Cancel

Note:

- The cameras should be in the connected status.
- If you click **Use Preset Camera Settings**, the camera uses the password and reset email configured in NVR Quick Setup. To view and modify the preset camera settings in NVR, go to **System > General Settings > User Management** in **Settings** and click [Icon] of the administrator.
- If you have added a camera to the NVR but cannot find it in the table, check the connection to make sure the camera is connected properly. Click **Refresh** to refresh the data.

4.6.3 Configure Scheduled Reboot

When Reboot Schedule is enabled, the camera reboots automatically and regularly at the specified time.

Note: The cameras should be in the connected status.

- Click the [Icon] menu button on the upper left corner to open the menu. Click **Camera**.
- Go to **Devices Added** page. Click the [Icon] icon in the Action column of the desired camera. Go to **System Management > Reboot Schedule**.
- Enable **Reboot Schedule**, and select the week day and reboot time. You can also set the float range. If you select Fixed Time, the NVR will restart precisely at the specified time. If you select Random

Delay, you can enter a value in the range of 1-60, and the NVR will reboot at a random time within the specified period after the scheduled time. Click **Apply**.

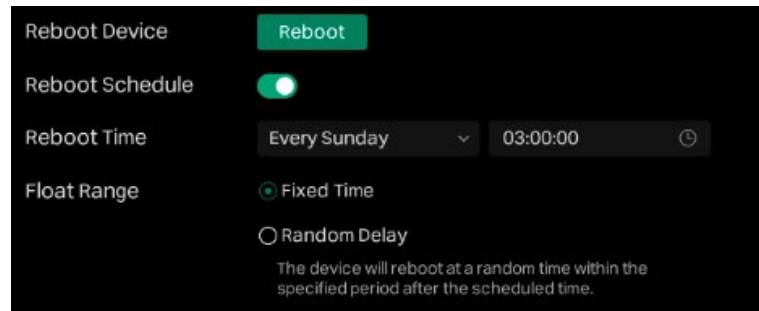



- (Optional) If you also want to apply the schedule settings to other channels, click **Copy to other devices** and select the channels.

4.6.4 Upgrade the Firmware

Two methods are supported to upgrade the firmware, Local Upgrade and Online Upgrade.

■ Update a device

Follow the steps below to update the firmware.

- Get ready to update the firmware.
 - (For Local Upgrade) Place the firmware in an external storage device and plug the external storage device into the NVR.
 - (For Online Upgrade) Connect the NVR and cameras to the internet first.
- Click the  menu button on the upper left corner to open the menu. Click **Camera**.
- Go to **Devices Added** page. Click the  icon in the Action column of the desired camera. Go to **System Management > Firmware Upgrade**.
- Select **Online Upgrade** or **Local Upgrade** to upgrade them.

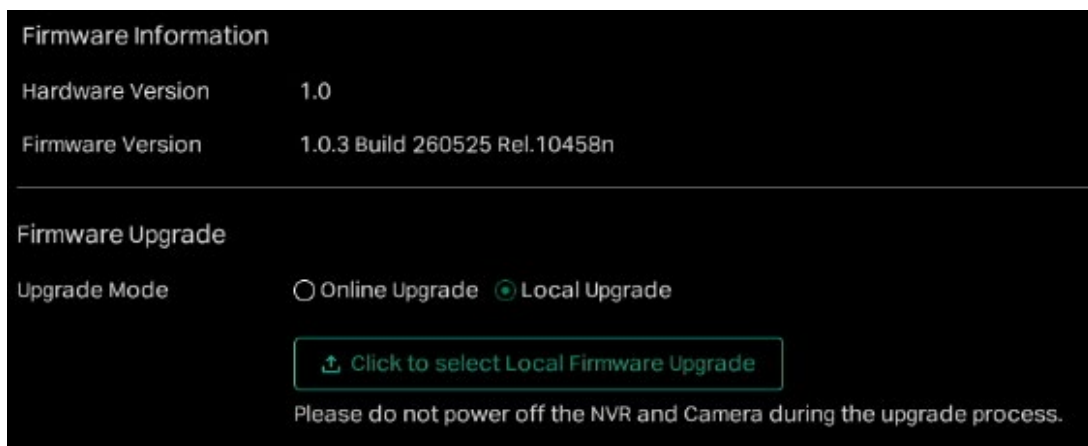

- For Online Upgrade, click to check the latest firmware and the device detects the new firmware online and upgrade automatically.
- For Local Upgrade, select the firmware from the external storage device and click **Upgrade**.

■ Update devices in batches

Follow the steps below to update the firmware in batches.

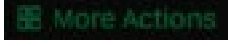
1. Get ready to update the firmware.
 - (For Local Upgrade) Place the firmware in an external storage device and plug the external storage device into the NVR.
 - (For Online Upgrade) Connect the NVR and cameras to the internet first.
2. Click the  menu button on the upper left corner to open the menu. Click **Camera**.
3. Go to **Devices Added** page. Select the desired cameras and click the  button, then click **Online Upgrade** or **Local Upgrade** to upgrade them.
 - For Online Upgrade, only the cameras with available firmware updates will be upgraded, Do not power off the NVR or cameras during the process..
 - For Local Upgrade, select the firmware from the external storage device and click **Upgrade**.

Note:

- The cameras should be in the connected status.
- Make sure to use the correct firmware to upgrade the corresponding camera.
- When updating, please do not turn off the power of camera and NVR.

4.6.5 Remove Cameras from the NVR

After removing the camera from the NVR, you cannot configure and manage it via NVR.

1. Click the  menu button on the upper left corner to open the menu. Click **Camera**.
2. Go to **Devices Added** page. Select the device and click the delete icon to remove this device.





Search

Search allows you to search videos in the recordings stored.

- [Search for Videos](#)

5.1 Search for Videos





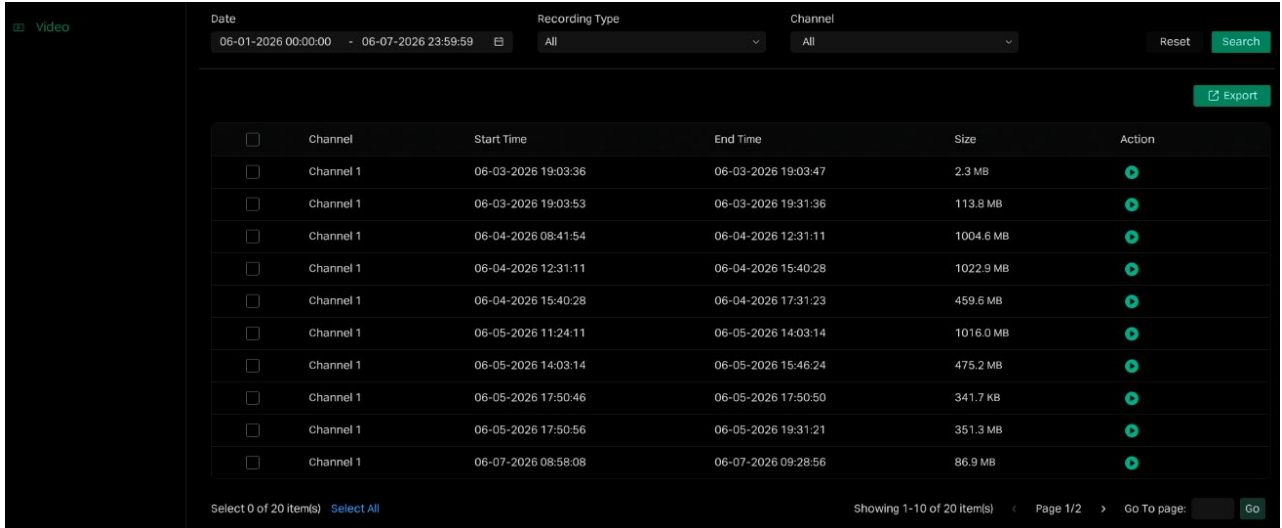





You can search for specific videos by specifying the filter type.

1. Click the  menu button on the upper left corner to open the menu. Click **Search**.
2. Select the date, select a channel, set the start time and end time, select the recording type, **All** or **Event Recording**, then click **Search**. You will see the search results displayed. Click  to play the video and you can click **Export** to export the videos as needed.



The screenshot shows a video search interface with the following elements:

- Filters:** Date (06-01-2026 00:00:00 - 06-07-2026 23:59:59), Recording Type (All), Channel (All), Reset, Search, and Export buttons.
- Table:** A table with columns: Channel, Start Time, End Time, Size, and Action. It contains 10 rows of search results.
- Footer:** Select 0 of 20 Item(s) Select All, Showing 1-10 of 20 Item(s), Page 1/2, Go To page: Go.

<input type="checkbox"/>	Channel	Start Time	End Time	Size	Action
<input type="checkbox"/>	Channel 1	06-03-2026 19:03:36	06-03-2026 19:03:47	2.3 MB	
<input type="checkbox"/>	Channel 1	06-03-2026 19:03:53	06-03-2026 19:31:36	113.8 MB	
<input type="checkbox"/>	Channel 1	06-04-2026 08:41:54	06-04-2026 12:31:11	1004.6 MB	
<input type="checkbox"/>	Channel 1	06-04-2026 12:31:11	06-04-2026 15:40:28	1022.9 MB	
<input type="checkbox"/>	Channel 1	06-04-2026 15:40:28	06-04-2026 17:31:23	459.6 MB	
<input type="checkbox"/>	Channel 1	06-05-2026 11:24:11	06-05-2026 14:03:14	1016.0 MB	
<input type="checkbox"/>	Channel 1	06-05-2026 14:03:14	06-05-2026 15:46:24	475.2 MB	
<input type="checkbox"/>	Channel 1	06-05-2026 17:50:46	06-05-2026 17:50:50	341.7 KB	
<input type="checkbox"/>	Channel 1	06-05-2026 17:50:56	06-05-2026 19:31:21	351.3 MB	
<input type="checkbox"/>	Channel 1	06-07-2026 08:58:08	06-07-2026 09:28:56	86.9 MB	

6

System

This chapter guides you on how to set NVR alarm settings, view and configure recording and storage settings on your NVR, configure network setting, the basic and advanced settings of your NVR, export and import settings, and view system logs and etc.,

- [Configure Alarm Settings](#)
- [Storage](#)
- [Configure Network Settings](#)
- [Configure General Settings](#)

6.1 Configure Alarm Settings

6.1.1 System Exception

Alarm actions will be triggered when the NVR detects disk problems, hard drive password error, IP conflict and so on. You can select triggered actions for these exception types. Follow the steps below to finish the configuration.

1. Click the  menu button on the upper left corner to open the menu. Under the **System** menu, Click **Alarm**.
2. Go to **Alarm > Exception Detection > System Exception**.

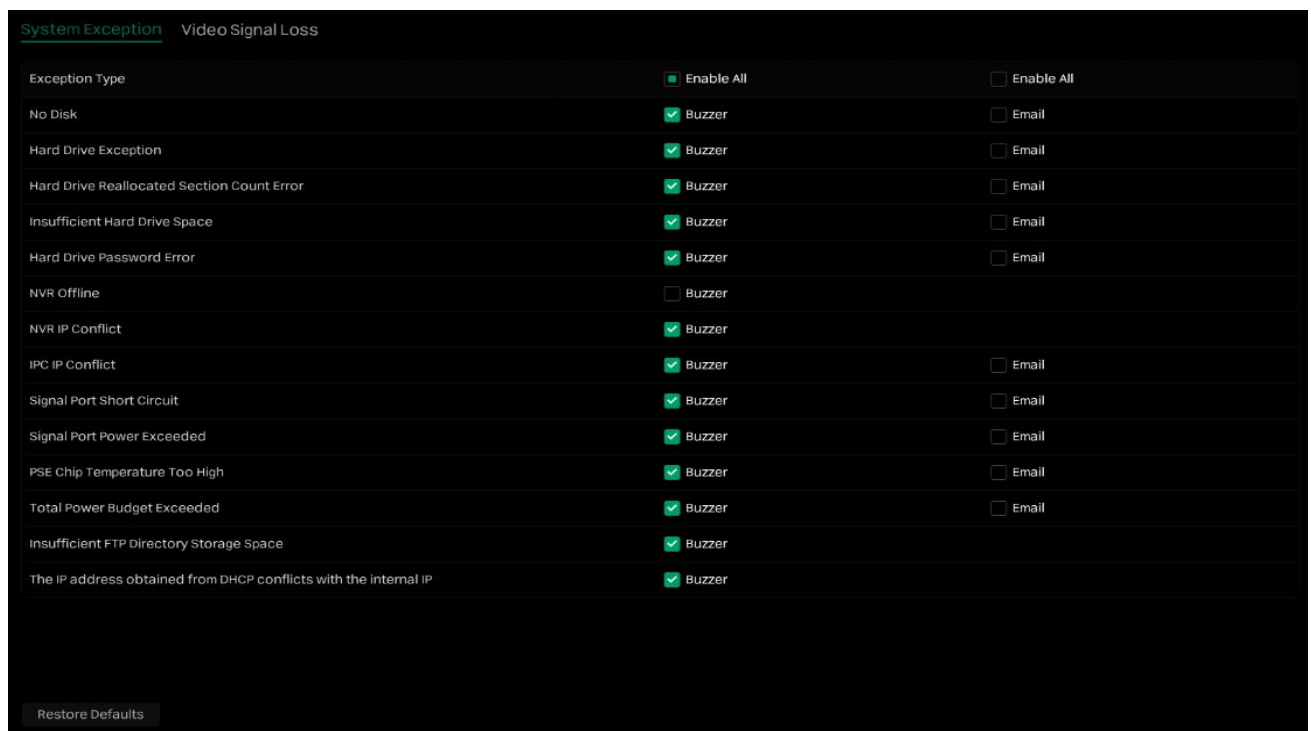

3. Enable the alarm actions for the desired exception types according to your needs, and click **Restore Defaults** to restore the settings to factory defaults.

Buzzer

The buzzer on the NVR will beep when the specific system problems are detected.

Email

The system will send an email when specific problems are detected.

6.1.2 Video Signal Loss

Alarm actions will be triggered when the NVR cannot get video signal from the camera and display signal on the Live View screen. You can customize the triggered actions for different cameras. Follow the steps below to finish the configuration.

1. Click the  menu button on the upper left corner to open the menu. Under the **System** menu, Click **Alarm**.

- Go to **Alarm > Exception Detection > Video Signal Loss**.

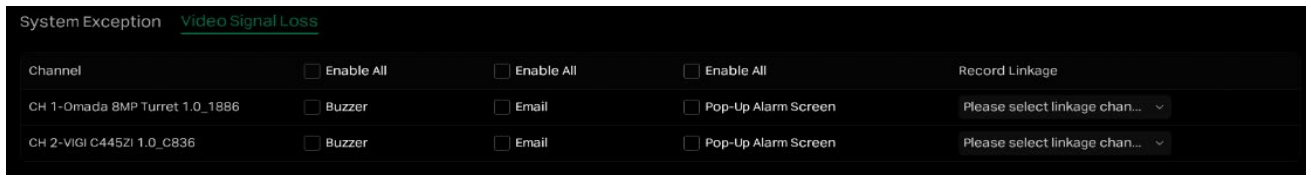

- Enable the alarm actions for the desired exception types according to your needs, and click **Restore Defaults** to restore the settings to factory defaults.

Buzzer	The buzzer on the NVR will beep when the NVR detects the signal loss.
Email	The system will send an email when the NVR detects the signal loss.
Pop-Up Alarm Screen	The channel in Live View will be in full screen when the NVR detects the signal loss.
Recording Linkage	Select the channel and select the camera. The cameras you select for recording linkage will start recording when the current channel detects the signal loss.

(For certain models) Select the alarm output interface. When the current channel detects the signal loss, the alarm output device connected to the NVR will be triggered.

Alarm Output Linkage

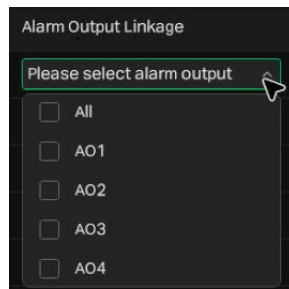

6.1.3 Alarm Device

Some NVRs and cameras support external alarm devices, which can be used to trigger alarms after NVR events, or to detect environmental abnormalities and provide abnormal signals. Connect your alarm device to the alarm interface.

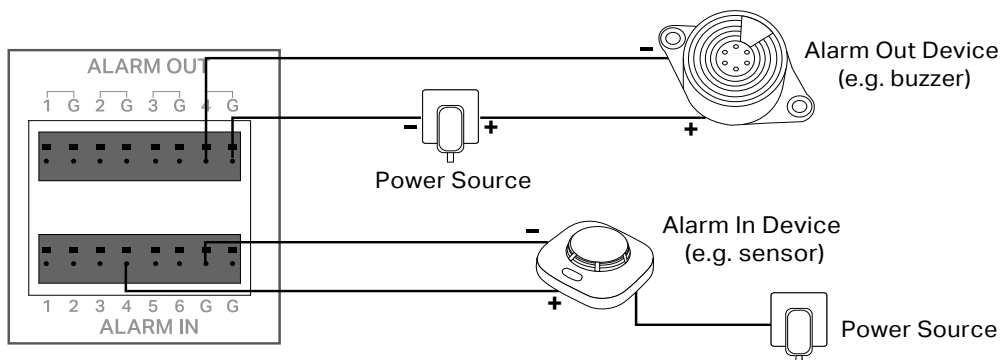

■ Alarm Input

1. Go to **Alarm Device > Alarm Input** to load the following page. This page will display the NVR's alarm input port number and the connected cameras that support alarm input.

Alarm Input Number	Alarm Name	Alarm Type	Enable Status	Action
AI1	AI1	<input type="radio"/> Normally Open <input checked="" type="radio"/> Normally Closed	<input type="checkbox"/>	
AI2	AI2	<input type="radio"/> Normally Open <input checked="" type="radio"/> Normally Closed	<input type="checkbox"/>	
AI3	AI3	<input type="radio"/> Normally Open <input checked="" type="radio"/> Normally Closed	<input type="checkbox"/>	
AI4	AI4	<input type="radio"/> Normally Open <input checked="" type="radio"/> Normally Closed	<input type="checkbox"/>	
AI5	AI5	<input type="radio"/> Normally Open <input checked="" type="radio"/> Normally Closed	<input type="checkbox"/>	
AI6	AI6	<input type="radio"/> Normally Open <input checked="" type="radio"/> Normally Closed	<input type="checkbox"/>	
CH1-AI1	AI1	<input checked="" type="radio"/> Normally Open <input type="radio"/> Normally Closed	<input type="checkbox"/>	

Showing 1-7 of 7 item(s) < Page 1/1 > Go To page:

2. You can modify the **Alarm Name** for the port as needed.
3. Enable this alarm input.
4. Set the alarm Type, **Normally Closed** or **Normally Open**. **Normally Open** means that under normal conditions, the circuit is open and no current passes through the NVR, when the alarm is triggered, the current passes through the NVR and the NVR alarms. **Normally Closed** means that normally the circuit is closed, and the NVR will alarm in case of a circuit fault or alarm trigger. This depends on the type of alarm input device.
5. Click the Settings button and select the mode, **Alarm** or **One-key Disarming**.
 - If you select **Alarm**, proceed to next step to configure the arming time and linkage method.
 - If you select **One-key Disarming**, it means the One-key Disarming can be activated by the input device, and you can refer to [Arming/Disarming](#) for further disarming action settings.

Edit Alarm Input ×

Mode: Alarm One-key Disarming

Note: You can go to System > Alarm > Arming/Disarming to set the disarming actions.

- 6. Configure the arming time and linkage method, then the Alarm input will only work during the set time period. You can click the Edit button to add time and quickly copy time to other days, click **Confirm** to save the time settings.

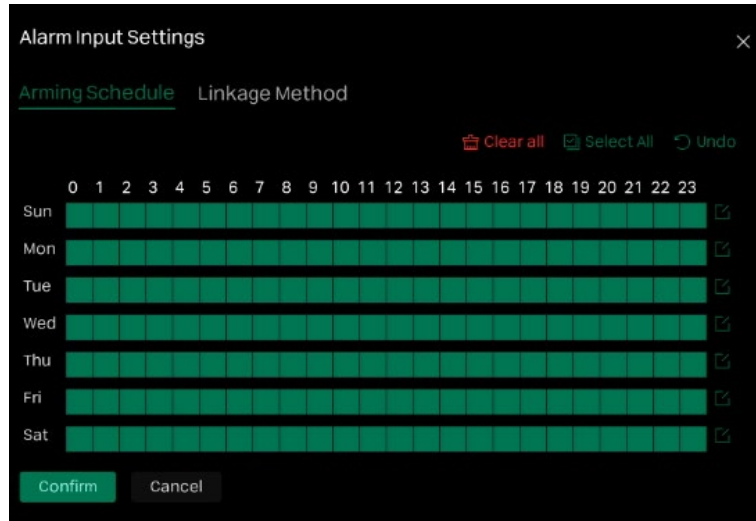

- 7. Click Linkage Method to configure the linkage method.

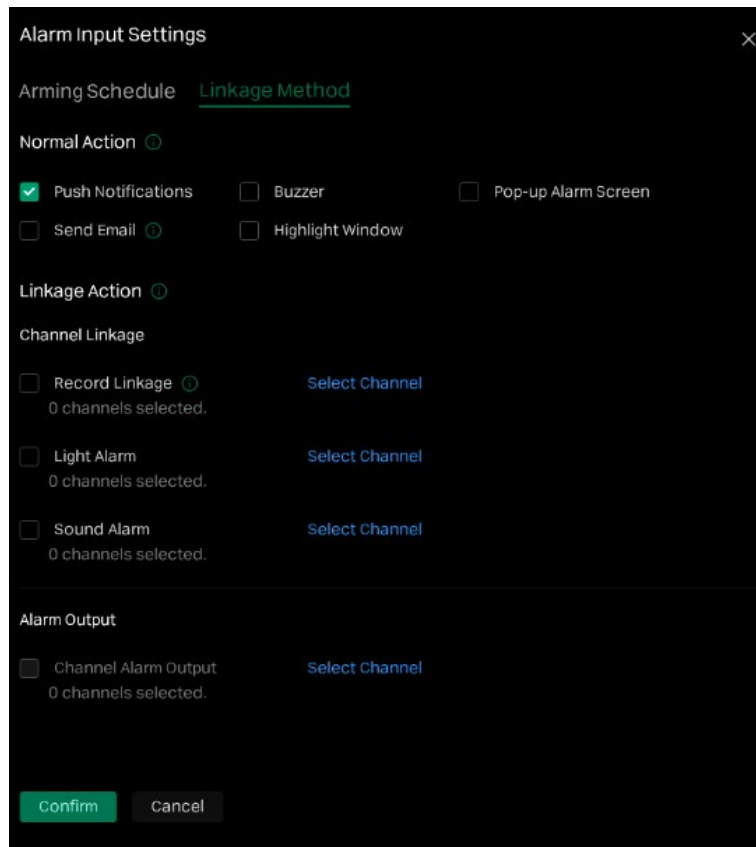

Push Notifications

The system will push notifications when the alarm is triggered.

Buzzer

The buzzer on the NVR will beep when the alarm is triggered.

Pop-up Alarm Screen	The channel in Live View will be in full screen when the alarm is triggered.
Send Email	The system will send an email when the alarm is triggered.
Highlight Window	The live view window will be highlighted when the alarm is triggered.
Recording Linkage	The channels you select for recording linkage will start recording when the alarm is triggered
Light Alarm	(Only supports camera models with light alarm) The camera will trigger light alarm when the alarm is triggered.
Sound Alarm	(Only supports camera models with audible alarm) The buzzer on the camera will alarm when the alarm is triggered.
Alarm Output	(Only supports camera models with audible alarm) The connected alarm output device will sound when the alarm is triggered.

■ Alarm Output.

1. Go to **Alarm Device** > **Alarm Output** to load the following page. This page will display the NVR's alarm output port number and the connected cameras that support alarm output.

Alarm Output Number	Alarm Name	Duration	Enable Status	Action
A01	A01	10s	<input type="checkbox"/>	
A02	A02	10s	<input type="checkbox"/>	
A03	A03	10s	<input type="checkbox"/>	
A04	A04	10s	<input type="checkbox"/>	
CH1-A01	A01	5s	<input type="checkbox"/>	

Showing 1-5 of 5 item(s) < Page 1/1 > Go To page:

2. You can modify the **Alarm Name** for the port as needed.
3. Set the **Duration** to specify how long the alarm will last.
4. Enable this alarm output.

- Click the Action button to configure the arming time, then the Alarm output will only work during the set time period. You can click the Edit button to add time and quickly copy time to other days, click **Confirm** to save the time settings.

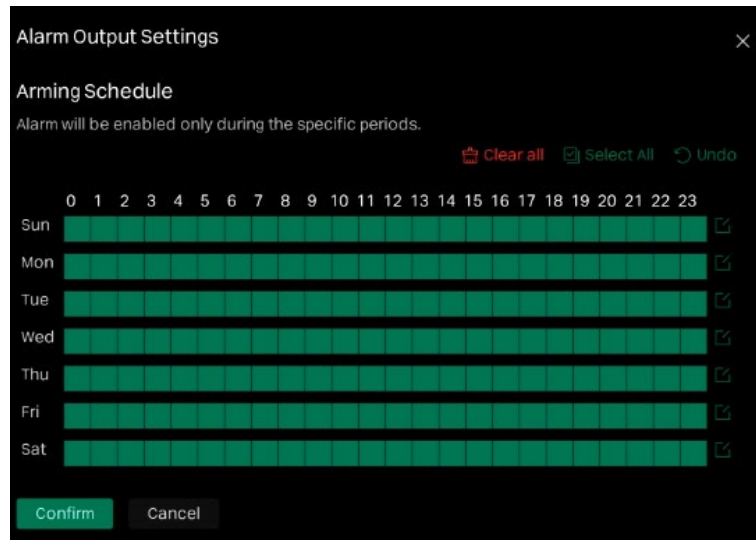

6.1.4 Arming/Disarming

In this module, you can configure the one-key arming/disarming settings and the one-time alarm/stop alarm settings.

■ One-Key Arming/Disarming

- Click the  menu button on the upper left corner to open the menu. Under the **System** menu, click **Alarm**.
- Go to **Alarm > Arming/Disarming**, and locate the One-Key Arming/Disarming section.

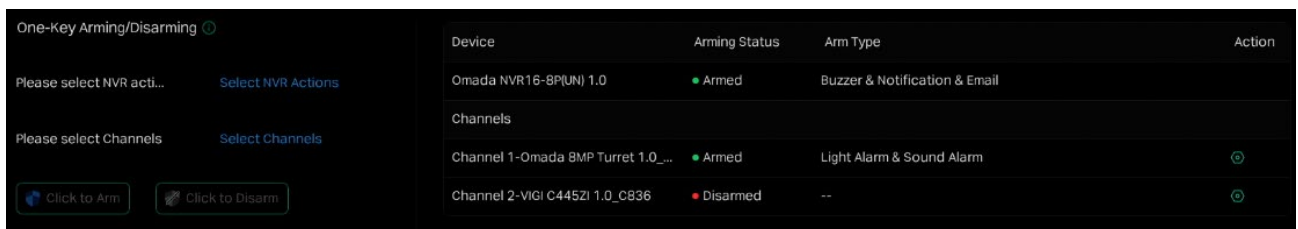

- Select NVR actions, **All** or a specific action.

Buzzer	The buzzer on the NVR will beep when the NVR detects an event.
Push Notifications	The system will push notifications when the NVR detects an event.
Email	The system will send an email when the NVR detects an event
Alarm Output	(For certain models) Select the alarm output interface. When performing one-key arming or disarming, the alarm output device connected to the NVR will be triggered.

4. Select the channel you want to execute the one-key arming/disarming. Click the Setting icon to configure the active defense settings.
 - Configure the light alarm

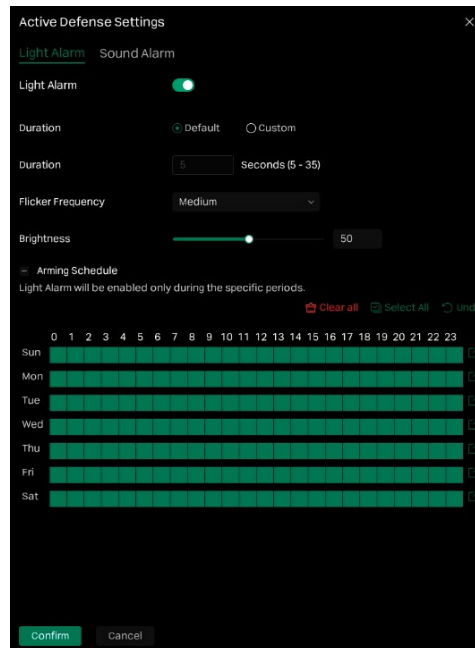

- 1) Toggle on to enable the light alarm, and configure the following parameters.

Duration	<p>Select the Duration mode.</p> <p>In the Default mode, once an event triggers the light alarm, the light will flash continuously as long as the event continues to trigger, with no time limit. Each event triggers only once, and each flash lasts 5 seconds.</p> <p>In the Custom mode, you can customize the light alarm duration. The default value in custom mode is 5 seconds, meaning the light will flash for 5 seconds after the event triggers the alarm and then stop. Users can customize the duration from 5 to 35 seconds.</p>
Flicker Frequency	<p>From the drop-down menu, choose a flicker frequency: Low, Medium, or High.</p>
Brightness	<p>Drag the slider to adjust brightness between 0 and 100. Higher values increase the brightness of the light alarm.</p>

- 2) Configure the arming schedule. You can click Edit to add time and quickly copy time to other

- Configure the sound alarm

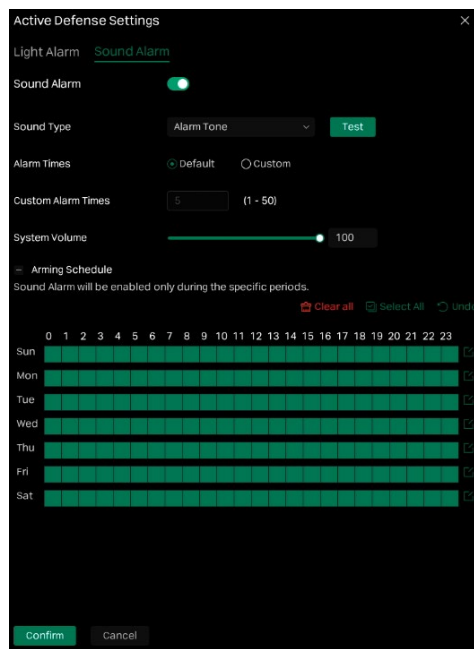

- 1) Toggle on to enable the sound alarm, and configure the following parameters.

Sound Type

Select the sound type from the drop-down list and click **Test** to try it.

Select the alarm times mode.

Alarm Times

In the Default mode, once an event triggers an alarm, the alarm audio will play continuously as long as the event continues, without any time limit.

In the Custom mode, you can customize the number of alarm sounds. The default value in custom mode is 5 sounds, meaning that the alarm audio will play 5 times after an event triggers an alarm. Users can customize the number of alarm sounds from 1 to 50.

System Volume

Click the toggle to mute or drag the slide bar to set the system volume.

- 2) Configure the arming schedule. You can click Edit to add time and quickly copy time to other
5. Now you can also click the corresponding button, Click to Arm or Click to Disarm to quickly perform operations. On the right, you can see the configuration details.

■ One-Time Alarm/Stop Alarm

1. Click the  menu button on the upper left corner to open the menu. Under the **System** menu, click **Alarm**.

- Go to **Alarm > Arming/Disarming**, and locate the One-Time Alarm/Stop Alarm section.

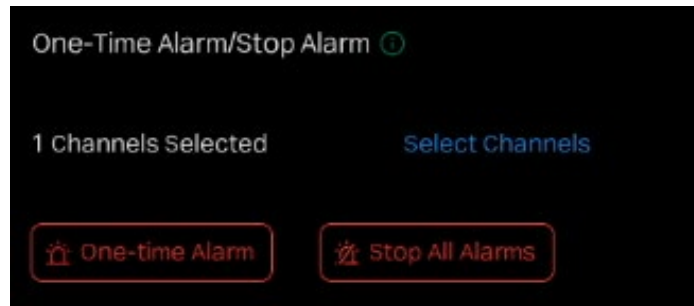

- Click the corresponding button, One-time Alarm or Stop All Alarms to quickly perform operations.

One-time Alarm	Click to trigger the alarm once.
Stop All Alarms	Click to stop all alarms immediately.

6.2 Storage

This section guides you on how to view and configure recording and storage settings on your NVR. Omada NVR allows you to set your own recording schedules and parameters, assign disk quota to connected cameras, manage and detect the installed hard drive, as well as export and back up recordings.

6.2.1 Configure Recording Schedules

Recording schedule section provides convenience and flexibility for the daily monitoring of your NVR. You can customize the recording schedule for all channels at a time or specify a recording schedule for certain channels. You can set different schedules for each day. In **Advanced Settings** page, you can set the pre-recorded time and delay time for recording.

- Click the  menu button on the upper left corner to open the menu. Under the **System** menu, click **Storage**.

- Go to **Storage > Recording Schedule**.

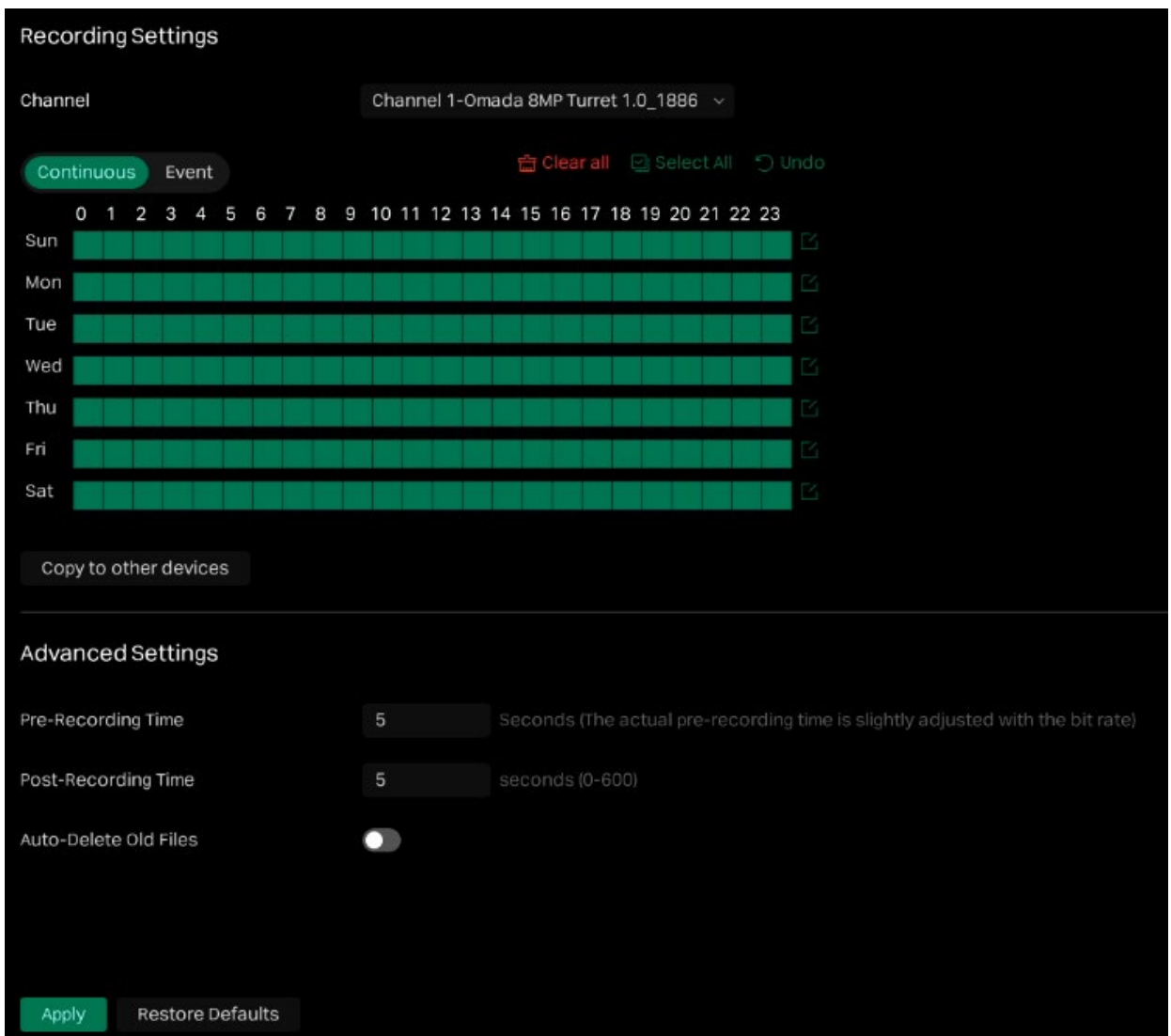

- Select the channel from the drop-down list.
- Enable **Recording Schedule**. By default, it is enabled.
- Customize the recording schedule. Directly click the time bar or click the edit button to set the recording type and time periods.

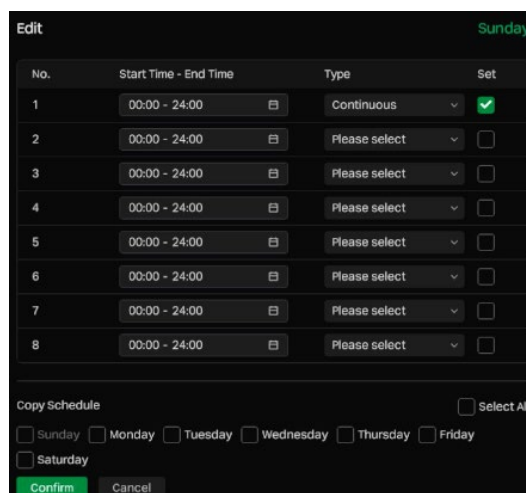

Note:

- Make sure the periods for different recording types are not overlapped.
- The scheduled time can be accurate to the minute.

6. You can click **Copy to other devices** to sync the recording schedule to other channels.
7. (Optional) To configure the pre-recorded and delay time for cameras, configure the advanced settings.

Pre-Recording Time

The time is set for cameras to record before the scheduled time or event. For example, the schedule for continuous recording starts at 10:00. If you set the pre-recording time as 5 seconds, the camera starts to record at 9:59:55.

Note: It is recommended to remain the default setting of 5 seconds

Post-Recording Time

The time is set for cameras to record after the scheduled time or event. For example, if you set the post-record time as 5 seconds, it records till 11:00:05 as motion detection ends at 11:00.

Auto-Delete Old Files

Enable this feature and set the maximum storage space. When the space of files reaches the set limit, the old files will be automatically deleted to store new files.

6.2.2 Recording Controls

1. Click the  menu button on the upper left corner to open the menu. Under the **System** menu, click **Storage**.
1. Go to **Storage > Recording Controls**.

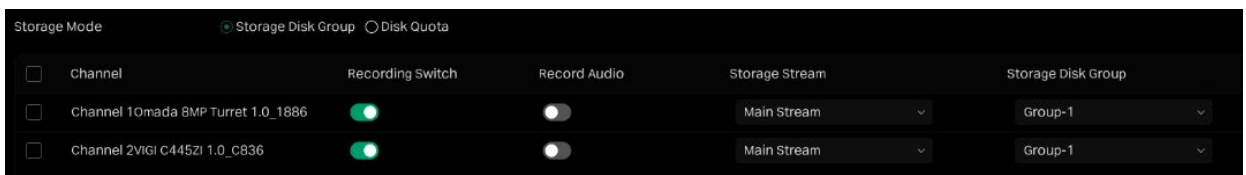

2. Select the **Storage Mode**, **Storage Disk Group** and **Disk Quota**.

■ Storage Disk Group,

In **Storage Disk Group**, you can manually start and stop recording on certain channels, select the storage stream for recording, and select the hard drive group. Select **Storage Disk Group**. Click **Save** after you finish the configuration.

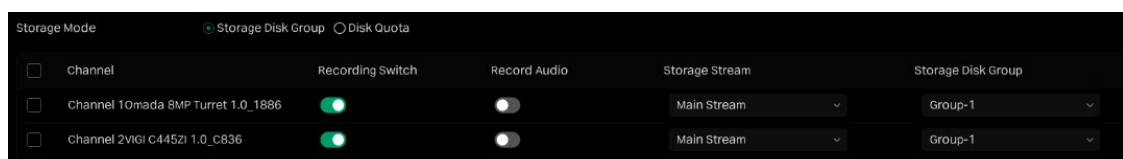
**Channel**

Displays the name of camera in this channel.

Recording Switch	Start/stop recording on the selected channel.
Record Audio	Start/stop recording audio on the selected channel.
Storage Stream	Select the stream for recording. Main Stream: The size of recording files will be larger when selected. Substream: The size of recording files will be smaller when selected. Both: The videos will be stored in main stream and substream. Substream+Main Stream (Event): Non-event videos will be stored in substream and the event videos will be stored in main stream.
Storage Disk Group	Select the disk group for the NVR with multiple hard drives.

■ Disk Quota

In **Disk Quota**, you can manually start and stop recording on certain channels, select the stream for the storage of recordings, check the used capacity of hard drive on certain channels, and assign the disk quota to cameras to store recordings.

To configure these settings, right click on the Live View screen and click **Settings** in the pop-up main menu. Then go to **Storage > Recording Controls** and select **Disk Quota**. Click **Save** after you finish the configuration.

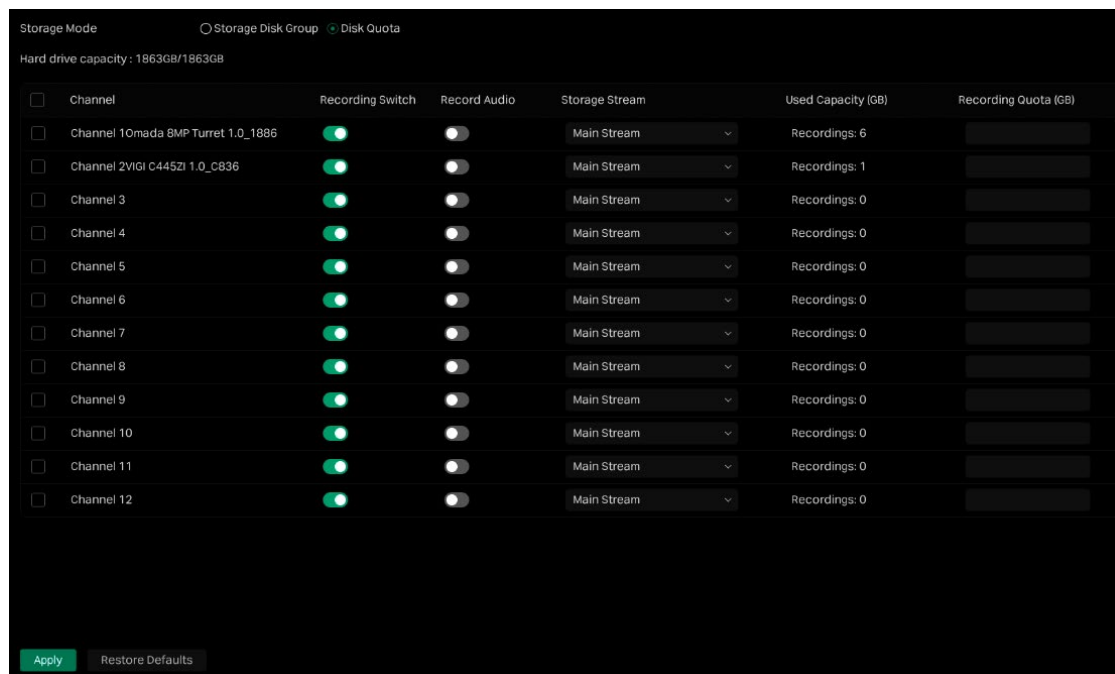

Channel	Displays the name of camera in this channel.
Recording Switch	Start/stop recording on the selected channel.
Record Audio	Start/stop recording audio on the selected channel.

	Select the stream for recording.
Storage Stream	Main Stream: The size of recording files will be larger when selected.
	Substream: The size of recording files will be smaller when selected.
	Both: The videos will be stored in main stream and substream.
	Substream+Main Stream (Event): Non-event videos will be stored in substream and the event videos will be stored in main stream.
Used Capacity	Displays the used space of hard drive for this channel.
Recording Quota	Assign the disk quota to your cameras for recording storage.

6.2.3 Hard Drive Management

In **Hard Drive Management**, you can view the parameters and configure the properties and disk group of hard drive. You can also enable the NVR to overwrite the earlier recording files when the hard drive is full.

1. Click the  menu button on the upper left corner to open the menu. Under the **System** menu, click **Storage**.
2. Go to **Storage > Hard Drive Management**.

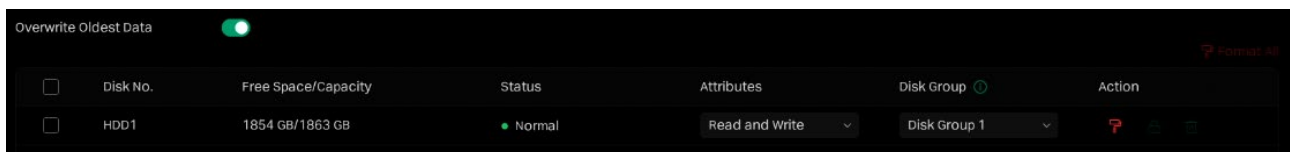

<input type="checkbox"/>	Disk No.	Free Space/Capacity	Status	Attributes	Disk Group	Action
<input type="checkbox"/>	HDD1	1854 GB/1863 GB	● Normal	Read and Write	Disk Group 1	

Overwrite Oldest Data	Enable the NVR to overwrite the earlier recording files when the hard drive is full.
Disk No.	Displays the number of hard drive.
Capacity	Displays the total space of hard drive.
Free Space	Displays the remaining storage capacity of hard drive.
Status	Displays the status of hard drive.
	Select the properties of hard drive.
Attributes	Read-write: The data can be read and written on the hard drive. Read-only: The hard drive can only read data.
Disk Group	Select the disk group for the NVR with multiple hard drives.

Click **Format** to format the hard drive. The data stored in the hard drive will be lost after you format it.

Action

Click the Lock button to verify the NVR encryption.

Click the Delete button to remove the hard drive..

■ Add an External Hard Drive to NVR

If you want to store more recordings on your NVR, add an external hard drive to expand its storage space. Connect an external hard drive to the SATA interface and then follow the steps.

1. Click the  menu button on the upper left corner to open the menu. Under the **System** menu, click **Storage**.
2. Go to **Storage > Hard Drive Management**. You will see the external hard drive found. Click + and the hard drive will be automatically added to your NVR.

Hard Drive Number	Free Space/Capacity	Action
USB-5	227 GB/232 GB	+

Note: The capacity of the external hard drive should exceed 120G.

6. 2. 4 Expansion Storage

Expansion storage uses key frame storage technology to compress the earlier videos and release a large amount of storage space, and thus increases the recording time. After expansion storage is enabled, select the expansion type based on your needs. Click the  menu button on the upper left corner to open the menu. Under the **System** menu, click **Storage**. Go to **Storage > Smart Storage > Expansion Storage**.

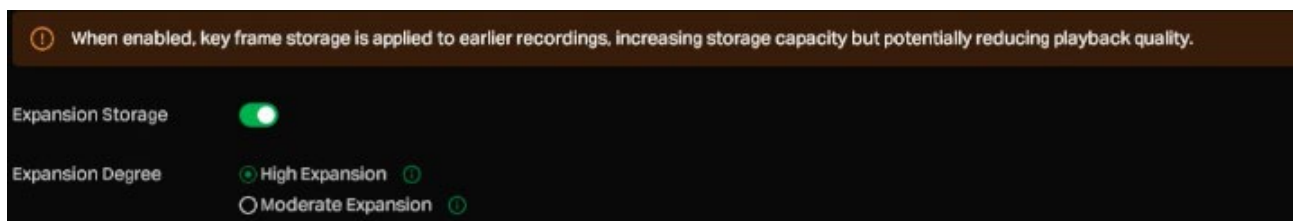

High Expansion

Extend the recording time to 3 times the original.

Moderate Expansion

Extend the recording time to twice the original.

6. 2. 5 Long-term Storage

Note:

If you have enabled Plug and Play, the long-term storage function cannot be enabled.

Long-term storage can reduce the size of recording files and extend the recording time by automatically changing the settings for recording and storage. To achieve this function, the NVR will adopt the following methods, including changing the smart coding type and bit rate type of camera, enabling expansion storage, after evaluating the hard drive capacity and the number of channels. After long-term storage is enabled, select the recording time you expect. Click the  menu button on the upper left corner to open the menu. Under the **System** menu, click **Storage**. Go to **Storage > Smart Storage > Long-term Storage**.

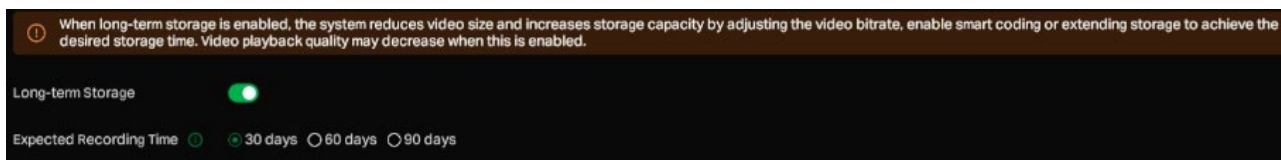

6.3 Configure Network Settings

With proper network configurations, you can connect your NVR to the internet, build up mapping between internal and external ports, and manage it remotely via Cloud Services.

6.3.1 Configure Connection Settings

In Connection, you can view the connection status and configure the NVR to obtain a dynamic or static IP address.

Follow the steps below to configure the basic settings.

1. Click the  menu button on the upper left corner to open the menu. Under the **System** menu, click **Network**.
2. Go to **Network > Connection**.
3. Select a mode and follow the instructions below.

- To assign a static IP address to NVR, select **Static IP** as the IPv4 mode and configure the following parameters.

The screenshot displays the NVR configuration interface. At the top, the status is 'Disconnected'. Below this is an 'Assign IP' button. The 'Basic Settings' section includes:

- IPv4 Mode: Static IP
- IPv4 Address: 192 . 168 . 0 . 117
- IPv4 Subnet Mask: 255 . 255 . 255 . 0
- IPv4 Gateway: 192 . 168 . 0 . 1
- Preferred DNS: 192 . 168 . 0 . 1
- Alternate DNS: 192 . 168 . 0 . 1
- IPv6 Enable: Disabled (toggle switch)

 The 'Advanced Settings' section includes:

- MTU: 1500

IPv4 Address Specify an IP address for the NVR. The IP address should be in the same segment as the gateway; otherwise, the NVR cannot connect to the internet.

Mask Enter the subnet mask.

Gateway Enter the IP address of the gateway device to which the data packets will be sent. This IP address should be in the same segment as the NVR's IP address.

Preferred/Alternate DNS Enter the IP address of the DNS server.

Note: You can toggle on to enable IPv6 and configure the corresponding parameters.

- To configure the NVR to obtain a dynamic IP address, select **Dynamic IP** as the mode.

Note:

- A DHCP server (usually a router) is needed for the NVR to obtain a dynamic IP address.
- If the topology or subnet is changed, you should assign a new IP address to the NVR to keep the network connection. In Static IP mode, configure the basic settings manually, while in Dynamic IP mode, click **Save**. Then follow step 3 below to change the IP addresses of cameras.

- (Optional) If the network segment of NVR is changed, click **Assign IP**, and then select the channels to change the IP addresses of cameras in batches. Click **Complete**.

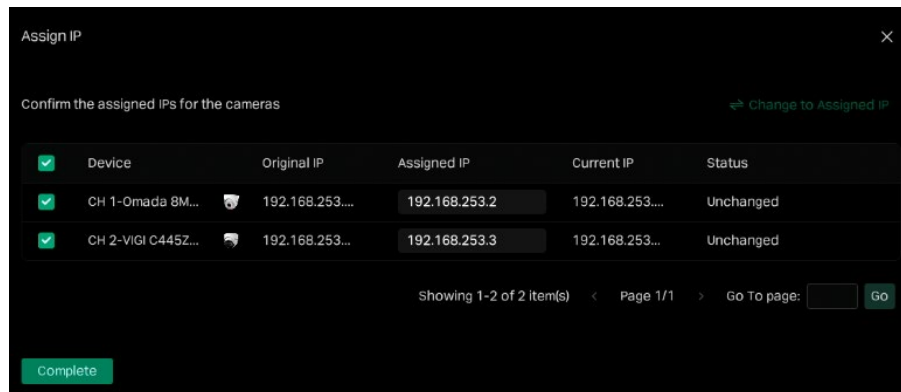

Note: The cameras should be in the same segment with the NVR, so that the NVR can discover and manage them.

- (Optional) Specify MTU (Maximum Transmission Unit) to decide the largest size of data unit that can be transmitted in the network. A larger unit can improve the efficiency with more data in each packets, but it may increase the network delay because it needs more time to transmit. Therefore, if you have no special needs, it is recommended to keep the default value.
- Click **Apply**.

If you want to reset to factory settings, click **Restore Defaults**.

6.3.2 Network Service

You can configure the HTTPS port, and service port of NVR that can be used to access the NVR through the network. When managing and monitoring the devices via other clients, the ports configured here are used for communications of corresponding protocols.

- Click the  menu button on the upper left corner to open the menu. Under the **System** menu, click **Network**.
- Go to **Network > Network Services**. Configure **HTTP(s)**, **RTSP(s)**, **ONVIF** and **Remote Registration** as needed.

■ HTTP(s)

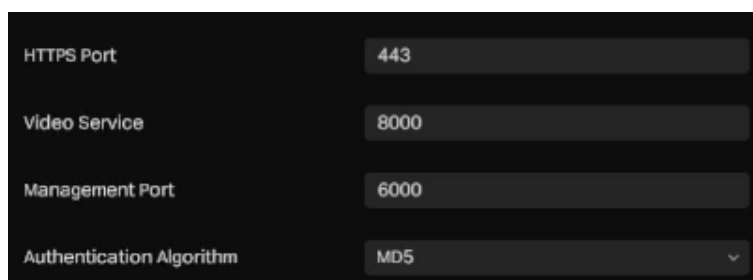

HTTPS Port

Specify a port for HTTPS protocol.

Video Service	Specify a port for protocols of video services.
Management Port	Specify a port to access the camera's live streaming web interface.
Authentication Algorithm	Select the authentication algorithm type from the drop-down list.

■ RTSP(s)

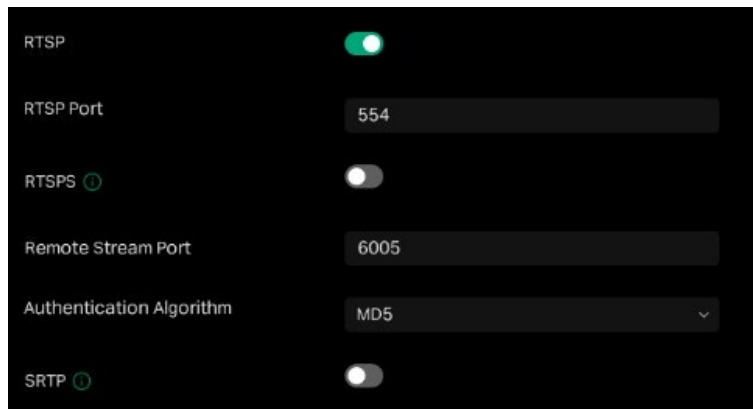

Specify a port for RTSP (Real Time Streaming Protocol) protocol.

RTSP is an application layer protocol for connecting, transferring, and streaming media data in real time from IP cameras connected to the network.

rtsp://username:password@ip:port/streamNo ip – IP of the Camera.

RTSP Port

port – Default port is 554. This can be skipped.

streamNo – Stream number. Stream1 refers to the main stream; stream2 refers to the substream.

Example URL: rtsp://admin:123456@192.168.1.60:554/stream1

This will display the main stream of the camera, where admin is the user name and 12345 is the password.

Specify a port for the RTSPS (RTSP over SSL) server.

RTSPS Port

RTSPS adds TLS encryption based on the RTSP protocol to ensure the security of data during network transmission and prevent it from being eavesdropped or tampered with.

Remote Stream Port

Default port is 6005. This can be skipped.

Authentication Algorithm

Select the authentication algorithm type from the drop-down list.

S RTP

When enabled, RTSP video data will be encrypted and you may be unable to play the video using third-party clients or NVRs.

■ ONVIF

Toggle on to enable ONVIF service.

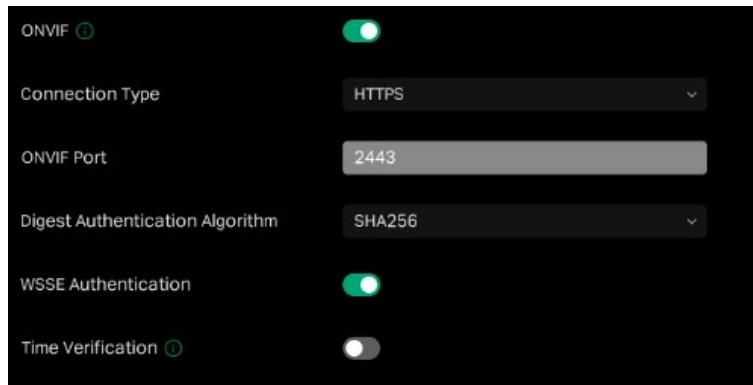
**Connection Type**

Select the network communication protocol between the external device and this device.

ONVIF Port

Specify a port for ONVIF protocol.

Digest Authentication Algorithm

Digest authentication refers to processing passwords and other information using a hash algorithm to generate a digest, preventing important information from being transmitted in plain text over the network. Set the algorithm used to verify digest information.

WSSE Authentication

Toggle on to enable WSSE Authentication. WSSE (Web Services Security Extension) is a protocol standard used to secure SOAP-based web service exchanges. It authenticates clients by passing encrypted credentials, a timestamp, and a nonce in a custom HTTP header, verifying requests without sending plain text passwords

Time Verification

Ensures secure ONVIF access by verifying time consistency between the device and the client.

Note: Before enabling Time Verification, make sure the device time is synchronized with the client to avoid authentication issues.

■ Remote Registration

The Remote Registration feature allows the NVR to connect to a remote management platform or server. This is typically used for centralized monitoring and management across different network segments.

Follow these steps to register the device to a remote server:

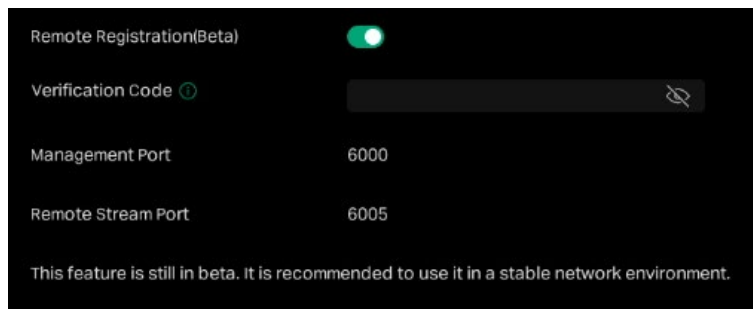

1. Toggle on to enable **Remote Registration**.
2. Enter the registration password required by the remote server in the Verification Password field.
3. Configure Ports:
 - 1) Management Port: Enter the port number used for device management communication (assigned by the server).
 - 2) Remote Stream Port: Enter the port number designated for video data transmission.
4. Click **Apply**.

6.3.3 Configure PoE Channel

In PoE channel, you can check the port status, rated power, change the port status and configure the port settings to determine whether the port can provide power supply.

1. Click the  menu button on the upper left corner to open the menu. Under the **System** menu, click **Network**.
2. Go to **Network > PoE Channel**.

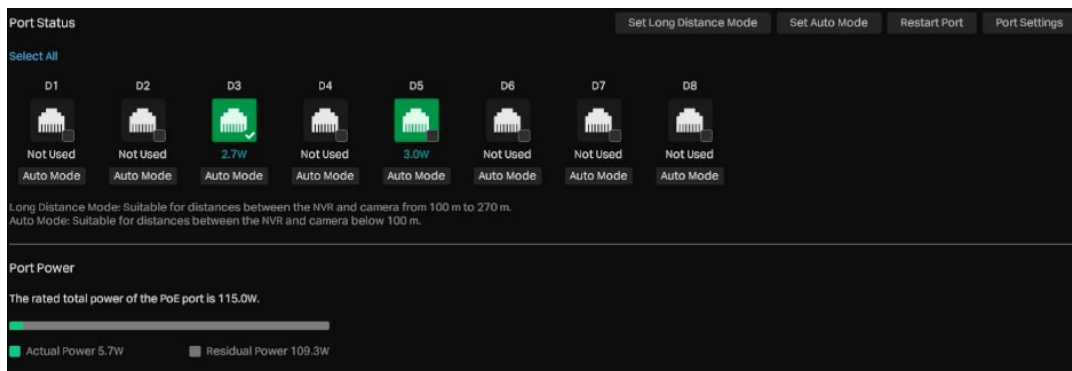

Port Status

Set Auto Mode: This mode is suitable for distance between NVR and camera below 100m.

Set Long Distance Mode: This mode is suitable for distance between NVR and camera from 100m to 270m.

Restart Port: Click to restart the selected PoE port, and the connected device will be temporarily disconnected from the NVR.

Port Settings

Click to configure port settings. Select the port, and set its power priority, power status and maximum power.

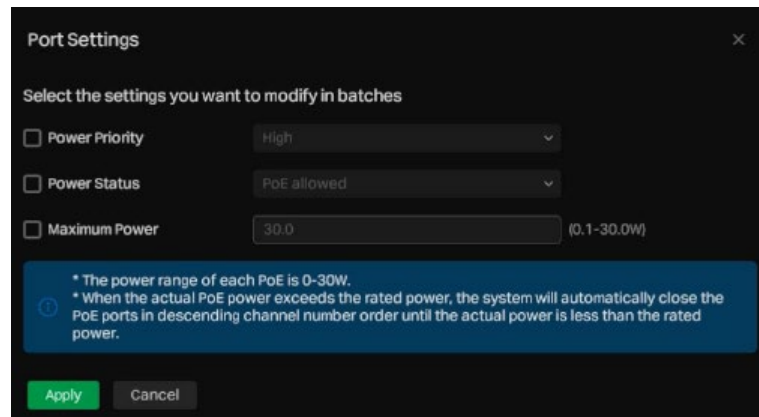

6.3.4 Configure Platform Access

You can enable Omada Cloud Service to allow adding device by scanning the device key of the device or enable inform url to enter the URL of your local Omada Guard application to enable device management by the local Omada Guard application. These two features cannot be enabled at the same time.

1. Click the  menu button on the upper left corner to open the menu. Under the **System** menu, click **Network**.
2. Go to **Network > Platform Access**.

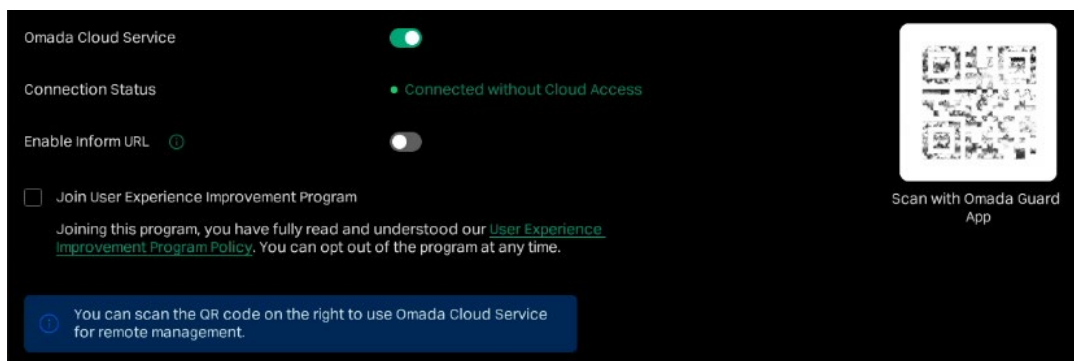

3. If you enable **Omada Cloud Service**, check the box to join our improvement program, and click **Apply**. Then you can scan the QR code with your Omada Guard app to add the camera and manage it remotely with the Omada Guard app.
4. If you **Enable Inform URL**, enter the Inform URL/IP Address of your Local Omada Guard Application to tell the device where to discover it. This feature is typically used in Layer 3 deployments to enable device management by Local Omada Guard Application. Check the box to join our improvement program, and click **Apply**.

6.3.5 Configure Email

Configure the email settings, then the system will send an alarm email to the designated recipient when an alert is triggered.

1. Click the  menu button on the upper left corner to open the menu. Under the **System** menu, click **Network**.
2. Go to **Network > Advanced > Email**.

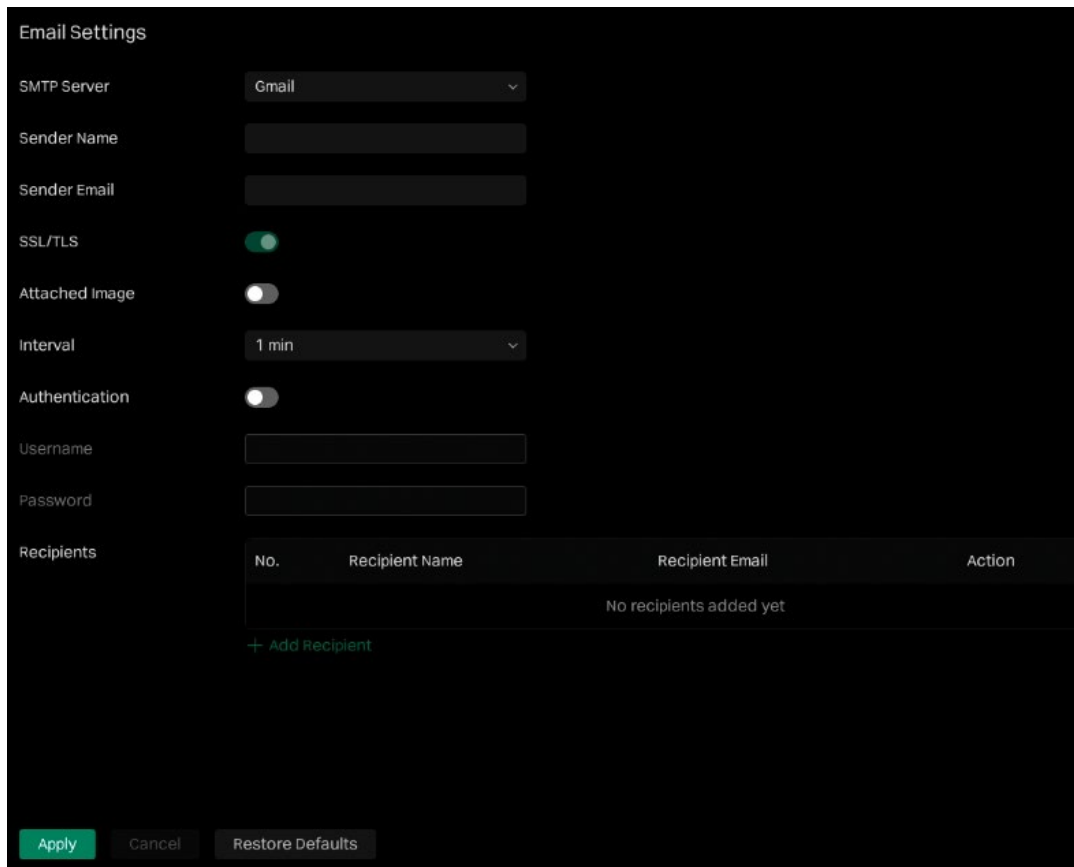

Email Settings

SMTP Server: Gmail

Sender Name:

Sender Email:

SSL/TLS:

Attached Image:

Interval: 1 min

Authentication:

Username:

Password:

No.	Recipient Name	Recipient Email	Action
No recipients added yet			

[+ Add Recipient](#)

Apply Cancel Restore Defaults

Sender Name	The name of the sender.
Sender Email	The email of the sender.
SMTP Server	Enter the SMTP server address. The format is smtp.x.com, where x represents the email name, such as smtp.gmail.com.
SMTP Port	Enter the port number of the SMTP server used for email alarms
SSL/TLS	Whether to use SSL/TLS protocol for encryption when sending email alarms.
Recipient Name	The name of the recipient.
Recipient Email	The email of the recipient.
Attached Image	Whether to attached the image with email.

Interval	Specify the interval to send emails.
Authentication	Whether to enable authentication.
Username	The username of the sending email account.
Password	The password of the sending email account. This password is generally an authorization code. Your email needs to enable the IMAP service to obtain the authorization code.

3. Click **Apply**.

6.3.6 Configure FTP

You can configure the FTP server to save images which are captured by events.

1. Click the  menu button on the upper left corner to open the menu. Under the **System** menu, click **Network**.

- Go to **Network > Advanced > FTP**. Toggle on to enable **FTP Backup**.

FTP Backup

FTP Server Settings
Configure the FTP Server and Directory.

FTP type FTP SFTP(Recommended)

Server Address

Port (1-65535)

Anonymous Anonymous

Username

Password

Upload path and edit the name

Generate Subfolder by

Example: 08-06-2026/Channel1

Video Settings
Select which video channels need to be uploaded and the type of video to be uploaded.

Video Type

Max File Size

- FTP and SFTP are selectable. SFTP is recommended, and by default the files uploading is encrypted by using SFTP protocol.
- Enter Server Address and Port. They stand for the FTP server address and corresponding port.
- Set Username and Password and confirm the password. The FTP user should have the permission to upload pictures.
- If the FTP server supports picture uploading by anonymous users, you can check Anonymous to hide your device information during uploading.
Note: Anonymous login is not supported when SFTP protocol is selected.
- Select the saving path of images uploaded in the dropdown box of Upload Path and Edit the Name.
- Click **Test FTP** to verify the FTP server.
- Configure the Video Types which will be saved to the FTP server. Specify the max file size, the video retention, and select the desired channel.

6.3.7 Configure DDNS

When you connect the router to a network, it will be assigned with a dynamic IP address and you can use this IP address to access the NVR. However, the IP address can change from time to time and you don't know when it changes. In this case, you might apply the DDNS (Dynamic Domain Name Server) feature on the NVR to allow you to access your NVR using a domain name without checking and remembering the IP address.

1. Click the  menu button on the upper left corner to open the menu. Under the **System** menu, click **Network**.
2. Go to **Network > Advanced > DDNS**.
3. Enable DDNS and specify the service provider, NO-IP, DynDNS or TP-Link DDNS. Enter the username, password and domain name of your account.

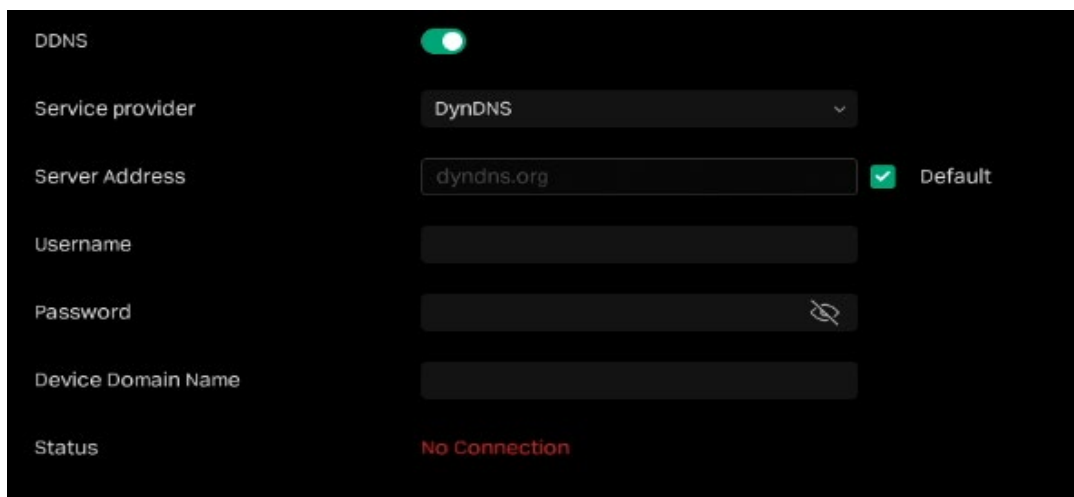



4. Click **Apply**.

6.3.8 Configure UPnP

UPnP is used to establish the mapping between the internal port and external port.

Note: The NVR and cameras should be connected to the internet, and UPnP should be enabled on the gateway.

1. Click the  menu button on the upper left corner to open the menu. Under the **System** menu, click **Network**.
2. Go to **Network > Advanced > UPnP**.

3. Enable UPnP and specify a mapping type. If you select **Auto** as the mapping type, the mappings are established automatically. If you select **Manual** as the mapping type, click  to specify the external port.

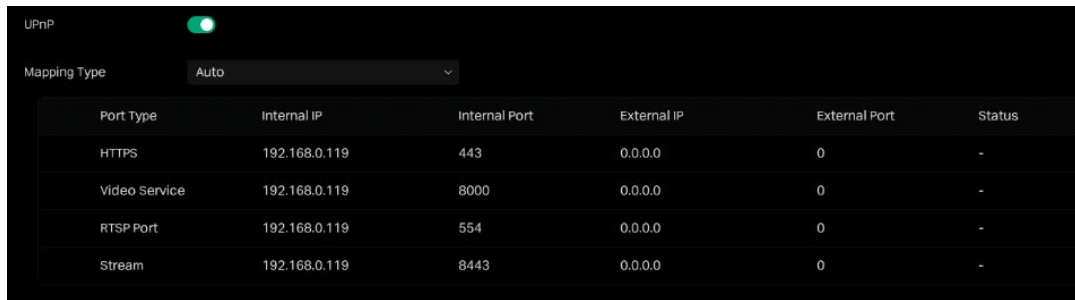

Port Type	Internal IP	Internal Port	External IP	External Port	Status
HTTPS	192.168.0.119	443	0.0.0.0	0	-
Video Service	192.168.0.119	8000	0.0.0.0	0	-
RTSP Port	192.168.0.119	554	0.0.0.0	0	-
Stream	192.168.0.119	8443	0.0.0.0	0	-

Port Type	Displays the protocol type.
Internal IP	Displays the IP address of the NVR that needs to be converted.
Internal Port	Displays the port of the NVR to be converted.
External IP	Displays the IP address of the NVR that will be converted to.
External Port	Displays the external port opened by the gateway.
Status	Displays the status of mapping.

4. Click **Apply**.

6.3.9 Configure LLDP

Enable LLDP to allow the NVR to advertise its own basic information and receive information from neighboring devices.

1. Click the  menu button on the upper left corner to open the menu. Under the **System** menu, click **Network**.
2. Go to **Network > Advanced > LLDP**. Toggle on to enable **LLDP**.



6.3.10 Configure SNMP

You can set the SNMP, or Simple Network Management Protocol, to get device information in network management.

1. Click the  menu button on the upper left corner to open the menu. Under the **System** menu, click **Network**.

2. Go to **Network > Advanced > SNMP**. Toggle on to enable **SNMP**.

The screenshot shows the SNMP configuration page with the following settings:

- SNMP v1:** Enabled (toggle on)
- SNMP v2c:** Enabled (toggle on)
- Read SNMP Community:** [Empty text field]
- Trap Address:** 192 . 168 . 0 . 1
- Trap Port:** 162
- SNMP Port:** 161
- SNMP v3:** Enabled (toggle on)
- Read User Name:** tplink
- Security Level:** auth, priv
- Authentication Algorithm:** SHA256
- Authentication Password:** [Empty text field]
- Private Key Algorithm:** AES256
- Private Key Password:** [Empty text field]

3. Enable your SNMP version according to your actual needs.
4. When enabling SNMPv1/SNMP v2c, enter the SNMP community name. Note that the access is Read only, meaning that the network management system can only view but not modify parameters of the specified view. Configure the following parameters.

Trap Address	IP Address of SNMP host.
Trap Port	Port of SNMP host. The value is by default 162 and can range from 1 to 65535.
SNMP Port	An SNMP communication endpoint that identifies SNMP data transfers. By default the SNMP port is 161.

5. When enabling SNMPv3, enter the Read User name. Note that the access is Read only, meaning that the network management system can only view but not modify parameters of the specified view. Configure the following parameters.

Security Levels	<p>no auth, no priv: No authentication or privacy is used. This offers the least security and is generally not recommended for production environments.</p> <p>auth, priv: Both authentication and privacy (encryption) are enabled. This offers the highest level of security, protecting both the sender's identity and the data being transmitted.</p> <p>auth, no priv: Authentication is enabled, but no encryption is used. This provides basic security by verifying the identity of the sender.</p>
Authentication Algorithm	SNMPv3 supports various authentication algorithms, including: MD5: Message Digest 5 (a widely used hash function). SHA: Secure Hash Algorithm (another hash function). SHA-256: A more secure version of SHA.
Authentication Password	A password used to verify the authenticity of the message sender. It should be strong and long (at least 8 characters).

Encryption Protocols: SNMPv3 supports encryption algorithms like:

DES: Data Encryption Standard.

Private Key Algorithm

AES: Advanced Encryption Standard.

AES192: Advanced Encryption Standard with 192-bit key.

AES256: Advanced Encryption Standard with 256-bit key.

Private Key Password

A password used to encrypt and decrypt the message payload.

6.3.11 Network Isolation

You can enable Network Isolation to isolate the NVR network from other devices, then other devices in the LAN cannot communicate with the NVR and its connected devices.

1. Click the  menu button on the upper left corner to open the menu. Under the **System** menu, click **Network**.
2. Go to **Network > Advanced > Network Isolation**.
3. Toggle on to enable **Network Isolation**, and configure the following parameters.

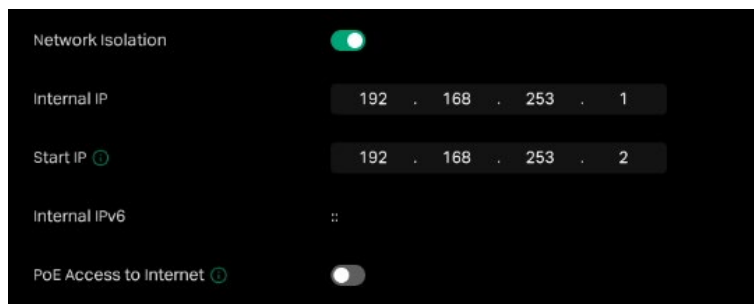

Internal IP

Specify the NVR's IP in a different subnet from other devices.

Start IP

Specify the start IP from which the NVR will use starting to assign to its connected devices.

PoE Access to Internet

When enabled, devices connected to the PoE ports can keep isolated from other devices and access the internet.

6.3.12 Configure IP Restriction

You can allow the Openapi connection to the NVR. Click the  menu button on the upper left corner to open the menu. Under the **System** menu, click **Network**. Go to **Network > Advanced > OpenAPI**. Toggle on to enable OpenAPI and enter the OpenAPI port.

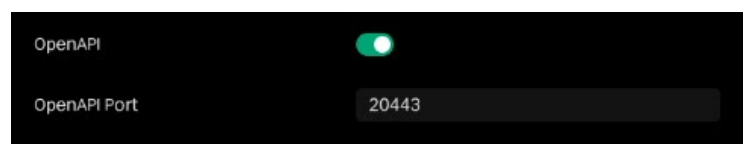

6.4 Configure General Settings

6.4.1 Configure Basic Settings

1. Click the  menu button on the upper left corner to open the menu. Under the **System** menu, click **General Settings**.
2. Go to **General Settings > Basic Settings > Basic Settings**.

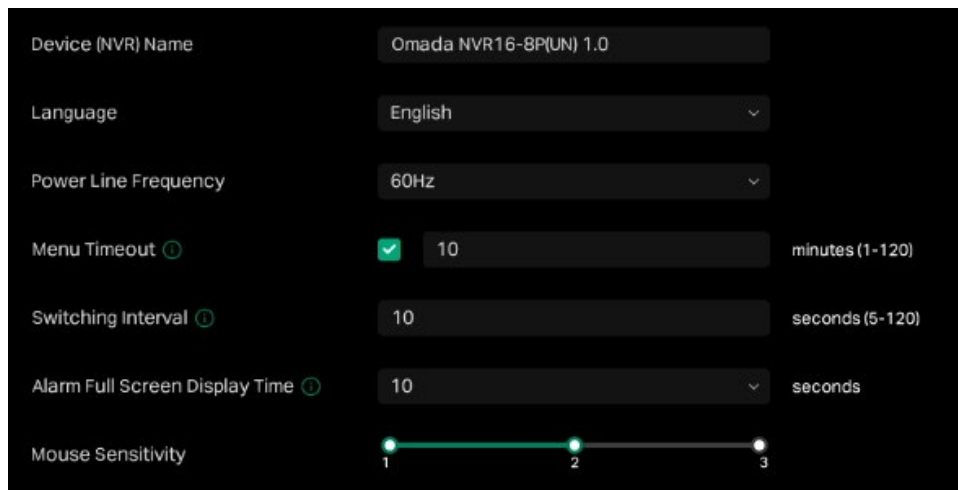

Device (NVR) Name	Displays the name of the NVR.
Language	Set the system language.
Power Line Frequency	Set the Power line frequency consistent with local utility settings to eliminate image flickering associated with fluorescent lights.
Menu Timeout	Set the time to control how long the login can be inactive on the NVR. By default, users already logging into the NVR are automatically logged out after 10 minutes.
Switching Interval	Set the interval for displaying the live view screen when switching is enabled. Click  on the right panel of the live view screen to start switching. The range is from 5s to 120s.
Alarm Full Screen Display Time	Set the dwell time of channels in full screen when events are detected.
Mouse Sensitivity	Determines the speed of a mouse pointer and how fast it moves on the screen.

6.4.2 Modify System Time

The NVR provides two methods to modify the system time. You can also select the time zone according to your region.

1. Click the  menu button on the upper left corner to open the menu. Under the **System** menu, click **General Settings**.
2. Go to **General Settings > Basic Settings > Date**.

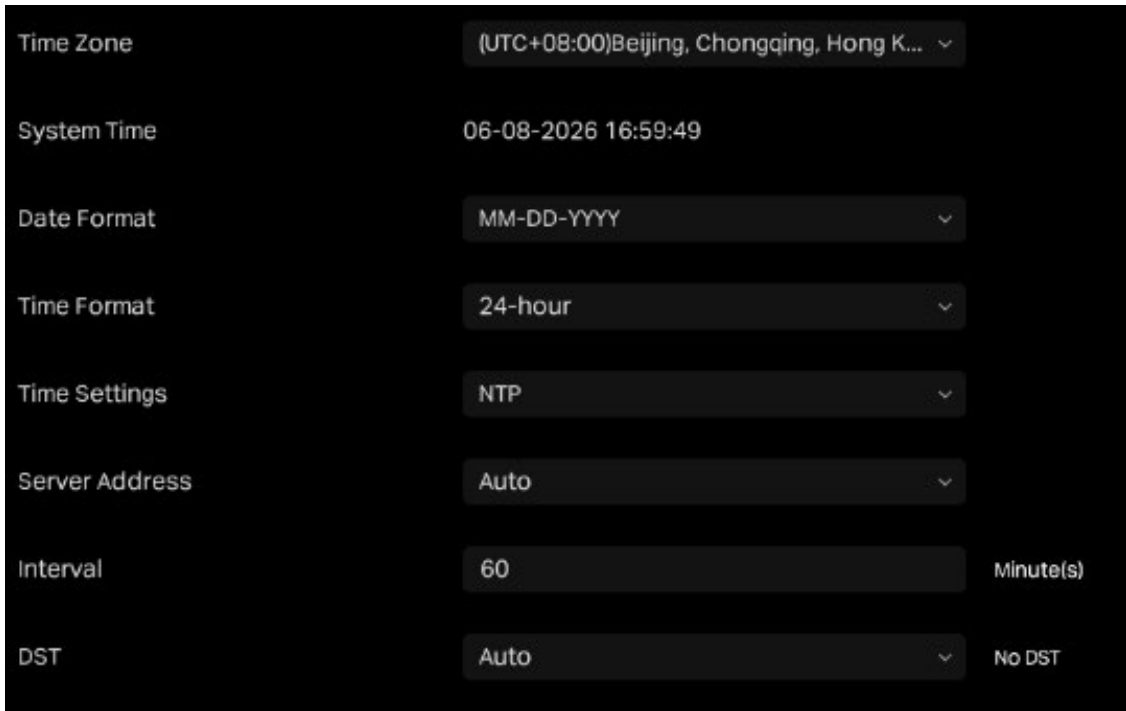

Time Zone	(UTC+08:00)Beijing, Chongqing, Hong K...	
System Time	06-08-2026 16:59:49	
Date Format	MM-DD-YYYY	
Time Format	24-hour	
Time Settings	NTP	
Server Address	Auto	
Interval	60	Minute(s)
DST	Auto	No DST

3. Select your time zone, date format and time format.
4. Select whether to use NTP (Network Time Protocol) to automatically get the system time from the Internet. It is recommended to keep the default server address or manually set the time.

6.4.3 Configure Interface Output

In Interface Output, you can select the display resolution for your monitor and choose to display the channel number on the Live View screen and the images in the original scale.

1. Click the  menu button on the upper left corner to open the menu. Under the **System** menu, click **General Settings**.

- Go to **General Settings > Basic Settings > Interface Output**.

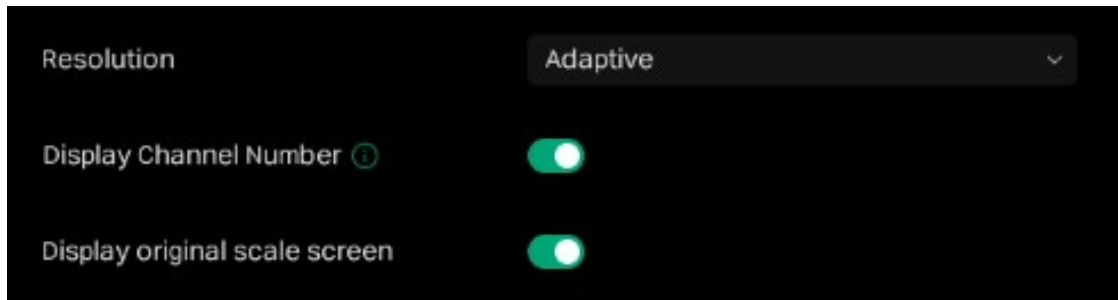

Resolution	Select the screen resolution according to your needs. With Adaptive selected, the NVR automatically selects the highest resolution supported by the screen.
Display Channel Number	Display the channel number on the Live View Screen.
Display Original Scale Screen	Display the images on the Live View screen in the original scale.

6. 4. 4 User Management

You can modify the default user account (admin) and create user accounts based on your needs. The administrator has the permission to add and delete other user accounts. The Administrator user name is admin and the password is set when you set up your NVR for the first time.

- Click the  menu button on the upper left corner to open the menu. Under the **System** menu, click **General Settings**.
- Go to **General Settings > User Management**.

■ Modify Administrator Account

For the administrator account, you have all the permissions to manage the NVR. Administrator user name is admin and the password is set when you set up your NVR for the first time. Click the edit icon to modify the settings.

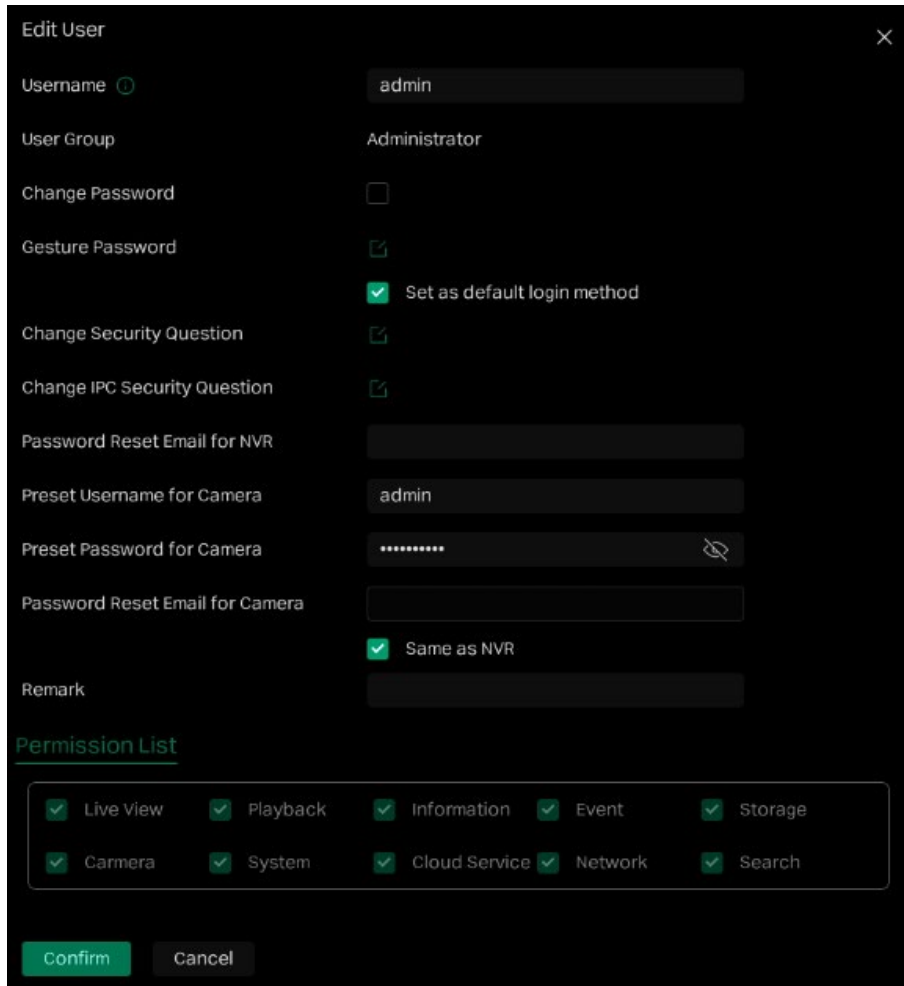

The screenshot shows the 'Edit User' dialog box for the administrator account. The interface is dark-themed. At the top, the title 'Edit User' is displayed with a close button (X) on the right. Below the title, several settings are listed:

- Username:** admin
- User Group:** Administrator
- Change Password:**
- Gesture Password:** Set as default login method
- Change Security Question:**
- Change IPC Security Question:**
- Password Reset Email for NVR:** [Empty text field]
- Preset Username for Camera:** admin
- Preset Password for Camera:** [Masked password field with a toggle icon]
- Password Reset Email for Camera:** Same as NVR
- Remark:** [Empty text field]

Below the settings is a section titled 'Permission List' with a list of permissions, each with a checked checkbox:

- Live View
- Playback
- Information
- Event
- Storage
- Camera
- System
- Cloud Service
- Network
- Search

At the bottom of the dialog, there are two buttons: 'Confirm' (highlighted in green) and 'Cancel'.

You can change the gesture password, the login password of NVR, the preset password for cameras and the email address for resetting NVR and cameras.

■ Add an Account

You can create user accounts with different permissions to manage the NVR. Follow the steps below to add a new user account.

3. Click **Add**. Enter the username and set the user level to **Operator** or **User**. The operator shares the same permissions as the administrator account. The user only watches the live view and playback.

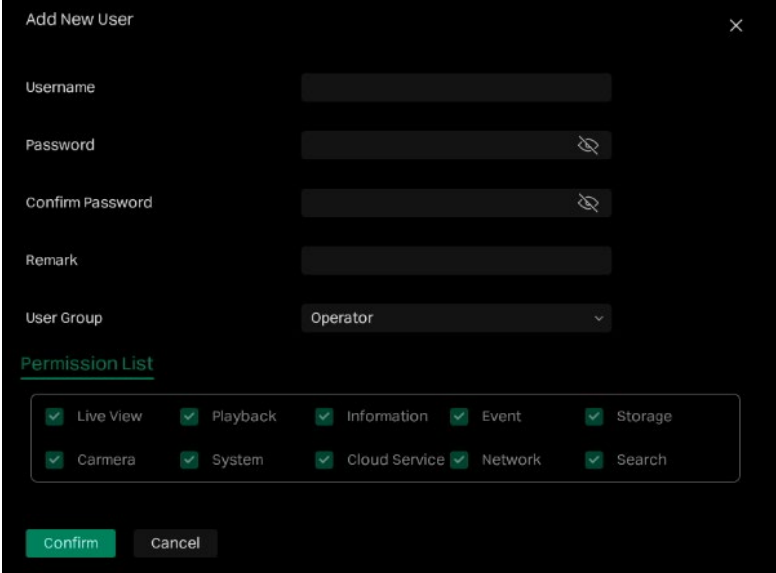

The screenshot shows a dark-themed 'Add New User' dialog box. It features a title bar with a close button (X). The form includes the following fields and options:

- Username:** A text input field.
- Password:** A password input field with a visibility toggle icon.
- Confirm Password:** A password input field with a visibility toggle icon.
- Remark:** A text input field.
- User Group:** A dropdown menu currently showing 'Operator'.
- Permission List:** A section with a title and a grid of 10 items, each with a checked checkbox:
 - Live View
 - Playback
 - Information
 - Event
 - Storage
 - Camera
 - System
 - Cloud Service
 - Network
 - Search
- Buttons:** 'Confirm' (highlighted in green) and 'Cancel'.

4. Set the password for logging in the account.
5. Click **Confirm**.

6.4.5 Firmware Update

The NVR supports Online Update and Local Update. Follow the steps below to upgrade the firmware.

1. Get ready to upgrade the firmware.
 - (For Online Update) Connect the NVR to the internet first.
 - (For Local Update) Download the NVR firmware from our official website, place the firmware in an external storage device and plug the external storage device into the NVR.
2. Click the  menu button on the upper left corner to open the menu. Under the **System** menu, click **General Settings**.

3. Go to **General Settings > Firmware Update**.

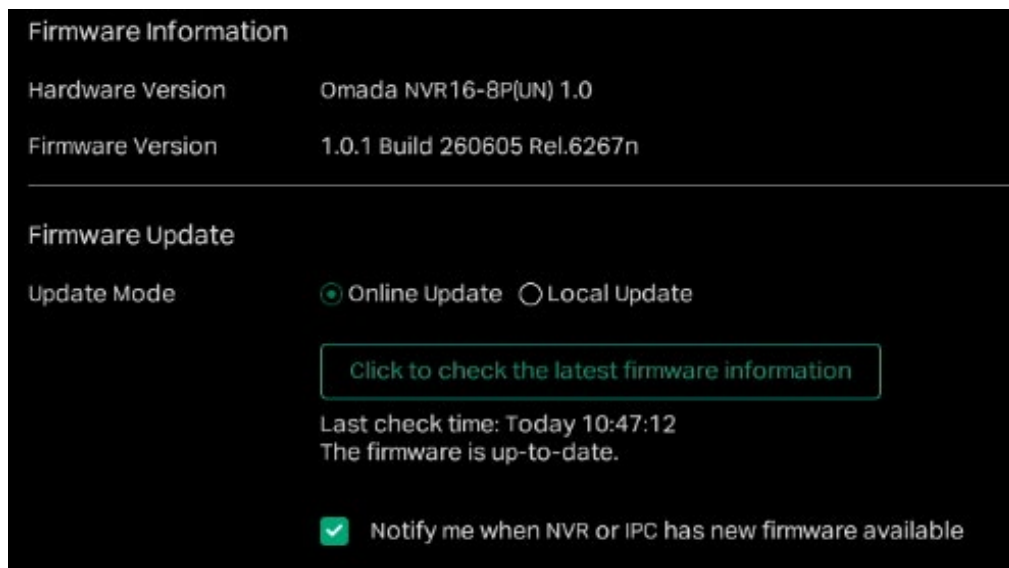

- (For Online Update) Click to check the latest firmware version and the NVR will detect new firmware online and upgrade automatically.
- (For Local Update) Click to select the firmware from the external storage device and click Upgrade.

Note: You can check the box to get a notification when NVR or IPC has new firmware available. When updating, do not turn off the power of NVR.

6.4.6 Maintenance

In Settings Management, click the corresponding buttons to reset the NVR, import configuration file, and export configuration file. When resetting, wait without any operations until the NVR is reset successfully. It may take a few minutes.

1. Click the  menu button on the upper left corner to open the menu. Under the **System** menu, click **General Settings**.
2. Go to **General Settings > System Management > Maintenance**. You can click **Reset** to restore the NVR to factory default settings, click **Export** to export the NVR's current configuration, or click **Import** to import a configuration file.

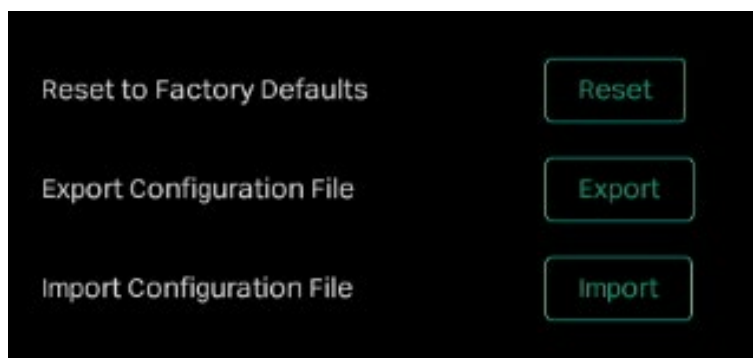

6.4.7 Reboot Schedule

When Reboot Schedule is enabled, the NVR reboots automatically and regularly at the specified time.

1. Click the  menu button on the upper left corner to open the menu. Under the **System** menu, click **General Settings**.
2. Go to **General Settings > System Management > Reboot**.
3. Toggle on to enable **Reboot Schedule**, and specify the week day and reboot time. You can also set the float range. If you select **Fixed Time**, the NVR will restart precisely at the specified time. If you select **Random Delay**, you can enter a value in the range of 1-60, and the NVR will reboot at a random time within the specified period after the scheduled time. Click **Apply**.

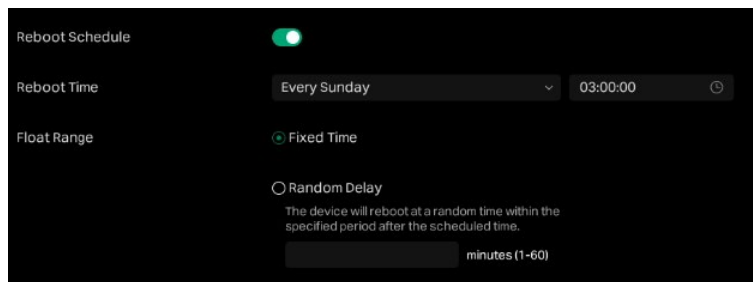

6.4.8 Login Settings

Set the maximum login attempts to protect the security of your camera. The camera will be locked for 30 minutes if you enter the wrong password more than the specified attempts.

1. Click the  menu button on the upper left corner to open the menu. Under the **System** menu, click **General Settings**.
2. Go to **General Settings > Security > Login Settings**.
3. Enable Login Attempt Limit and set the maximum login attempts. The number should be between 3 and 10.

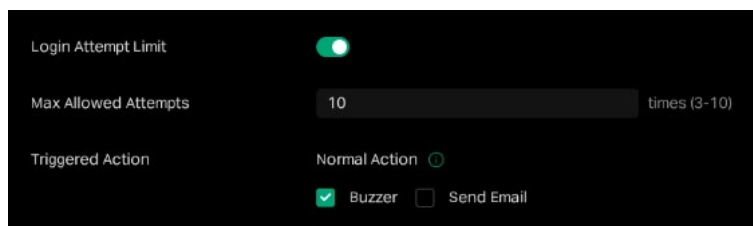

4. Select the triggered action, if the number of logins reaches the limit, the action will be triggered.
5. Click **Apply**.

6.4.9 IP Restriction

You can manage a Deny List or an Allow List to control which devices are permitted to access the NVR. This function supports filtering by IP Address.

1. Click the  menu button on the upper left corner to open the menu. Under the **System** menu, click **General Settings**.
2. Go to **General Settings > Security > IP Restriction**.
3. Enable IP Restriction and specify the restriction rule. If you select Deny List, the devices with the IP addresses specified in the table will not be able to access the NVR. If you select Allow List, only the devices with the IP addresses specified in the table can access the NVR.

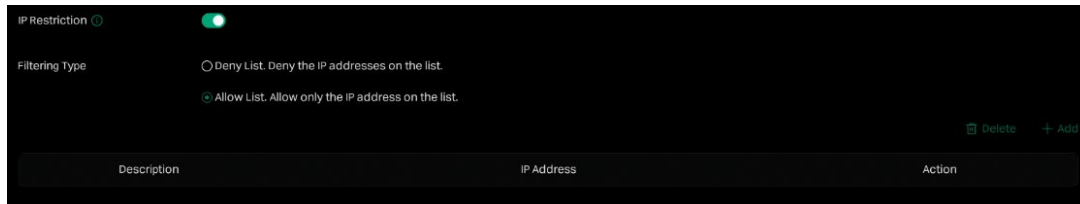

4. Click **Add** to add the desired IP address, give a description to identify this IP address, and click **Save**.

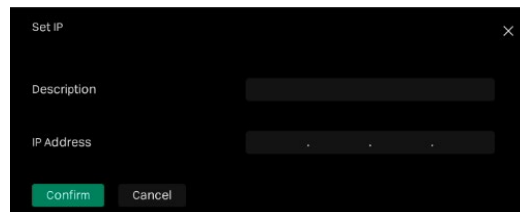

5. Click **Apply**.

6.4.10 System Log

The NVR uses logs to record, classify, and manage the messages of the system and devices. You can search, view, and export the logs.

Note: To export logs, an USB external storage device is required.

1. Click the  menu button on the upper left corner to open the menu. Under the **System** menu, click **System Log**.

2. Specify the time range and log types and click **Search**. The filtered logs appear in the table.

No.	Type	Recording Time	Details
1	Local login	06-08-2026 16:43:18	Local User: admin
2	Local login	06-08-2026 16:26:55	Local User: admin
3	Local login	06-08-2026 13:48:52	Local User: admin
4	IP channel connection	06-08-2026 11:06:04	Channel No: 1; URL: rtsp://192.168.253.206:554/stream1; State: Channel Connect.
5	RTSP progress	06-08-2026 11:06:04	Channel No: 1; URL: rtsp://192.168.253.206:554/stream1 rtsp://192.168.253.206:554/stream2; State: Create C...
6	Remove IP channel	06-08-2026 10:57:02	Local User: admin; Channel Number: 1; IP Address: 192.168.253.206
7	RTSP progress	06-08-2026 10:57:01	Channel No: 1; URL: rtsp://192.168.253.206:554/stream1; State: Delete Channel.
8	Remove IP channel	06-08-2026 10:52:36	Local User: admin; Channel Number: 1; IP Address: 192.168.253.206
9	RTSP progress	06-08-2026 10:52:35	Channel No: 1; URL: rtsp://192.168.253.206:554/stream1; State: Delete Channel.
10	IP channel connection	06-08-2026 10:52:27	Channel No: 1; URL: rtsp://192.168.253.206:554/stream1; State: Channel Connect.

Showing 1-10 of 56 item(s) < Page 1/6 > Go To page: Go

Date

Specify a time range to filter the logs based on the recording time.

Type

Select a main type from the drop-down list to filter the logs. You can also click **Select Subtypes** to specify subtypes.

All: All types of logs.

Alarm: Alarms triggered by events, such as tampering, line crossing, and area intrusion.

Exception: Abnormal events that may influence NVR's functions, such as video signal lost and errors of hard drive.

Operation: Operations that take place on the NVR, such as login and upgrade.

Information: Informational messages, such as local drive information and RTSP progress.

3. Click **Export** and select a file path in the pop-up window. Click **Export**. Note that an external storage device is required to use this feature